

Eritrea:

Essential Education Indicators

2004/05



Eritrea: Essential Education Indicators 2004/2005



MINISTRY OF EDUCATION
ASMERA, ERITREA
DECEMBER 2005

Table of contents

| Contents | Page |
|--|-----------|
| I. Introduction and Executive Summary..... | 1 |
| 1. Introduction | |
| 2. Executive Summary | |
| 3. Data Channels | |
| II. Important notes | 3 |
| 1. Population | |
| 2. Area of the country | |
| 3. School system | |
| 4. Dependency ratio | |
| 5. Definitions | |
| III. Introductory information..... | 5 |
| IV. Pre-primary level..... | 7 |
| 1. Pre-primary schools | |
| 2. Pre-primary enrolment | |
| 3. Pre-primary teachers | |
| V. Elementary level..... | 10 |
| 1. Duration | |
| 2. Enrolment | |
| 3. Gross admission ratio | |
| 4. Net admission ratio | |
| 5. Over-age pupils in grade 1 | |
| 6. Under-age pupils in grade 1 | |
| 7. Children out of school | |
| 8. Gross enrolment ratio | |
| 9. Net enrolment ratio by region | |
| 10. Disparities among the regions | |
| VI. Middle level..... | 17 |
| 1. Duration | |
| 2. Enrolment | |
| 3. Gross enrolment ratio | |
| 4. Net enrolment ratio | |
| 5. Percentage of repeaters | |
| VII. Secondary level..... | 20 |
| 1. Duration | |
| 2. Enrolment | |
| 3. Gross enrolment ratio | |
| 4. Net enrolment ratio | |
| 5. Percentage of repeaters | |
| VIII. Internal efficiency..... | 23 |
| 1. Length of school year | |
| 2. Elementary level percentage of repeaters | |
| 3. All grades flow rates | |
| 4. Elementary level: Flow rates | |
| 5. Middle level: Flow rates | |
| 6. Secondary level: Flow rates | |
| 7. Elementary level: Zoba flow rates | |
| 8. Elementary level: Cohort reconstruction – Eritrea and Regions | |

| | Page |
|---|-------------|
| IX. Elementary, middle and Secondary level: Teaching staff | 28 |
| 1. Elementary, middle and secondary level: pupil/teacher ratio. | |
| 2. Teachers' qualification | |
| 3. Female teachers | |
| X. Age-specific enrolment 2004/05..... | 30 |
| XI. Expenditure on education 2005..... | 31 |

Charts and figure

| | |
|--|-----------|
| Chart 1. Pre-primary: Enrolment year by gender | 8 |
| Chart 2. Elementary level: Enrolment by region and gender | 11 |
| Chart 3. Gross and net admission ratios by year and gender | 12 |
| Chart 4. Elementary level: Enrolment by year and gender | 14 |
| Chart 5. Elementary level: Gross enrolment ratio by year | 15 |
| Chart 6. Elementary level: Net enrolment ratio by year | 16 |
| Chart 7. Elementary level: Gross enrolment ratio by region 2004/05 | 16 |
| Chart 8. Middle level: Enrolment by region and gender | 17 |
| Chart 9. Middle level: Enrolment by year and gender | 18 |
| Chart 10. Secondary level: Enrolment by region and gender | 20 |
| Chart 11. Secondary level: Enrolment by year and gender | 21 |
| Chart 12. Secondary level: GER and NER by gender and year | 22 |
| Figure 1. Elementary level: Hypothetical cohort reconstruction (Constant) - Eritrea | 26 |
| Chart 13. Elementary level: Average length of study per student (ALSS) by Region | 27 |
| Chart 14. Percentage of wastage due to dropout and repetition by Region | 27 |
| Chart 15. Percent of female teachers 1991-2003/04 | 29 |
| Chart 16. Education: Recurrent expenditure 2005 | 32 |
| Chart 17. Education: Capital Expenditure 2005 | 32 |
| Chart 18. Education: Recurrent and Capital Expenditure | 33 |

Tables

| | |
|--|-----------|
| Table 1. Enrolment by level and gender 1991/92-2004/05..... | 5 |
| Table 2. Number of teachers by level and gender 1991/92-2004/05..... | 6 |
| Table 3. Non-government enrolment as percentage of total enrolment..... | 7 |
| Table 4. Pre-primary level: Location and ownership, 2004/05..... | 7 |
| Table 5. Pre-primary level: Age-group and gross enrolment ratio, 1991/92-2004/05 | 8 |
| Table 6. Pre-primary level: Age-group and net enrolment ratio in 2004/05..... | 8 |
| Table 7. Pre-primary level: Teachers and training status..... | 9 |
| Table 8. Pre-primary level: Pupil/teacher ratio 1991/92-2004/05..... | 9 |
| Table 9. Pre-primary level: Percentage of female teachers 1991/92-2004/05 | 10 |
| Table 10. Elementary level: Enrolment by region and gender..... | 10 |
| Table 11. Elementary level: Gross admission ratio 1991/92-2004/05..... | 11 |
| Table 12. Elementary level: Net admission ratios 1991/92-2004/05..... | 12 |
| Table 13. Elementary level: Enrolment and percentage of over-age pupils in grade 1..... | 13 |
| Table 14. Elementary level: Enrolment and percentage of under-age pupils in grade 1..... | 13 |
| Table 15. Elementary level: Net enrolment and children out of school 1991/92-2004/05..... | 14 |
| Table 16. Elementary level: Gross enrolment ratio 1991/92-2004/05..... | 14 |
| Table 17. Elementary level: Net enrolment and net enrolment ratio 1991/92-2004/05..... | 15 |
| Table 18. Elementary level: Gross enrolment and deviation from the national ratio by region.. | 15 |
| Table 19. Elementary level: Net enrolment and deviation from the national ratio by region.. | 16 |
| Table 20. Middle level: Enrolment by grade, gender and region (Gov. and non gov.)..... | 17 |
| Table 21. Middle level: Gross enrolment ratio 1991/92-2004/05..... | 18 |
| Table 22. Middle level: Gross enrolment ratio by region 2004/05..... | 18 |
| Table 23. Middle level: Net enrolment ratio 1991/92-2004/05..... | 19 |
| Table 24. Middle level: Net enrolment ratio by region 2004/05..... | 19 |
| Table 25. Middle level: Total number and percentage of repeaters 1991/92-2004/05..... | 19 |

| Contents | Page |
|--|-------------|
| Table 26. Secondary level: Enrolment by gender and region (Gov. and non-gov.)..... | 20 |
| Table 27. Secondary level: Gross enrolment ratio 1991/92-2004/05..... | 21 |
| Table 28. Secondary level: Gross enrolment ratio by region..... | 21 |
| Table 29. Secondary level: Net enrolment ratio: 1991/92-2004/05..... | 22 |
| Table 30. Secondary level: Net enrolment ratio by region..... | 22 |
| Table 31. Secondary level: Total number and percentage of repeaters by region 1991/92-2004/05..... | 23 |
| Table 32. Elementary level: Duration of school year | 23 |
| Table 33. Elementary level: Enrolment, repeaters and ratio of repetition by gender. 1991/92-2004/05..... | 24 |
| Table 34. All grades: Flow ratios by gender and grade 2004/05..... | 24 |
| Table 35. Elementary level: Flow ratios 2004/05..... | 24 |
| Table 36. Middle level: Flow ratios 2004/05..... | 25 |
| Table 37. Secondary level: Flow ratios 2004/05..... | 25 |
| Table 38. Elementary level: Average flow ratios 2004/05..... | 25 |
| Table 39. Eritrea Elementary level Wastage, survival and transition ratios. | 27 |
| Table 40. Teachers: Gender and level by region 2004/05..... | 28 |
| Table 41. Pupil/teacher ratio by year and level..... | 28 |
| Table 42. Teachers' qualifications..... | 29 |
| Table 43. Number and percentage of female teachers by level 1991/92-2004/05..... | 29 |
| Table 44. Age-specific enrolment 2004/05..... | 30 |
| Table 45. Education Recurrent Expenditure: 2005..... | 31 |
| Table 46. Education Capital Expenditure: 2005 | 33 |
| Table 47. Education Other expenditure 2005 | 33 |
| Table 48. Education Total Recurrent and Capital expenditure 2005..... | 33 |

I. Introduction and Executive summary

1 Introduction

‘Eritrea: Essential Education Indicators is the official, annual education publication of the Ministry of Education (MOE) dealing with basic essential indicators. This is the ninth report produced by the Department of Research and Human Resource Development in terms of organization of schools in the new six administrative regions, the Zobas. The sources of information for this publication are annual school censuses carried out by Zoba education offices through standard questionnaires filled by each school.

This publication covers Early Childhood Education (ECE) General Education (Elementary, Middle and Secondary levels), Adult Education, Technical Vocational Education and Training. The main purpose of the 2004/05 publication is to provide relevant, reliable and up-to-date information on education in Eritrea. It will thus serve as a source of useful information for the various stakeholders within and outside the education sector.

The data presented in this publication is comprehensive and detailed. It is expected to be useful for planning, decision making and for conducting research. Nevertheless, the Ministry of Education is making further efforts to improve the quality, timeliness, and coverage of the education statistics.

This publication would not have been possible without the valuable contributions of the six Zoba education offices and the other educational institutions. We remain deeply indebted to all of them for their commendable efforts and collaboration.

We are grateful to UNICEF: Eritrea office for its support in printing this publication. We also extend our appreciation to all those who have provided us with feedbacks.

Please feel free to give us your comments regarding the content and format of this education abstract, so that we may in the future attend to your requirements more adequately.

Department of Research and HRD
Ministry of Education
Asmera

December 2005

2. Executive summary

In the 2004/05 academic year enrolment in elementary education has increased by 0.7 percent and enrolment in elementary special needs education has increased by 3.95 as compared to 2003/04. The increase in elementary enrolment has mainly been witnessed in the Debub, Maekel, and Semienawi Keih Bahri regions. Enrolment at the middle level has increased by 13.1%. This has mainly taken place in the Debub, Maekel and Semienawi Keih Bahri regions. Enrolment in Secondary schools has increased by 9.6%, with almost all the regions registering increases at this level.

Enrolment of girls in elementary education in 2004/05 in Eritrea, as compared to 2003/04, has increased by 1.0 percent, and enrolment of girls in government schools has increased by about 0.5 percent.

As compared to 2003/04, the national enrolment of girls and boys in 2004/05 has increased by 4.4 percent. However, the participation ratio of girls is still lower than that of boys, except in the literacy programme, where the participation of women stands at 88.4 percent. The Gross Enrolment ratios of female pupils in pre-primary, elementary, middle and secondary schools have been 50.2 percent, 44.4 percent 38.8 percent and 34.2 percent respectively.

The numbers of schools, students and teachers in pre-primary education have increased by 196 percent, 68.5 percent and 71.7 percent respectively. The number of schools has increased by 0.9 percent at the elementary level and by 10.2 percent at the middle school level, while at the secondary level it has increased by 26.1 percent. The numbers of teachers at the elementary and secondary levels decreased by 1.1 percent and 2.1 percent respectively, while at the middle school level it has increased by 9.2 percent.

The national gross enrolment rates in 2004/05 were 16.3 percent, 71.73 percent, 48.4 percent and 24.0 percent in pre-primary, elementary, middle and secondary education respectively. Enrolment in special needs education has increased by approximately 4 percent.

The total number of schools in the 2004/05 academic year has been 870. These have comprised of 764 elementary schools, 205 middle schools and 58 secondary schools.

3 Data channels

The information in this statistical abstract is gathered mainly from routine Questionnaires 7, 8 and 9. The first two are closed questionnaires, in which schools and institutions send back the *November data* on pre-primary, primary, secondary, special, technical schools and TTI's to the MOE. The data include educational expenditure, adult literacy and evening classes. The expected time of completion of these questionnaires is April. In every academic year normally 100% of the questionnaires are collected.

Routine Questionnaire 9 mainly relates to a school's physical, financial and internal efficiency particulars. The expected time of completion of this Questionnaire is July, after the end of each academic year in the country.

We assure users of this abstract that all means have been pursued to make the information provided in this issue very highly valid and reliable.

Data in all tables, unless otherwise stated, refer to the 2004/05 academic year. Table numbers are sub-grouped under corresponding sections. Charts are sequenced in a continuous ascending order all through the abstract.

II. Important notes

1. Population

- 1.1 For the purpose of this issue the population estimate 3,397,515 is used to derive essential educational indicators, it is also used in splitting the population into single age population.

We would like to remind users of our yearly abstracts that we have been using different population estimation in our previous publications. We have used the new population estimation, which is considered to be a better estimation, as a base to calculate school-age population and thus enrolment and other essential indicators as well.

- 1.2. Average **population density**: 27/sq.km.

- 1.3. Total **school-age population** by school level (estimated percentage of the total population for the year 2004).

| Age group | Population | Estimated % of total population |
|-----------|------------|---------------------------------|
| 5-6 | 191,368 | 5.63 |
| 7-11 | 526,266 | 15.48 |
| 12-14 | 287,129 | 8.45 |
| 15-18 | 316,466 | 9.31 |

2. **Area of the country**: approximately **122,000 sq. km.***

*Source: EDHS 2002

3. School system

| Level | Grade | Age |
|------------|-------|-------|
| Pre-school | I, II | 5-6 |
| Elementary | 1-5 | 7-11 |
| Middle | 6-8 | 12-14 |
| Secondary | 9-12 | 15-18 |

4. **Dependency ratio** defined as percentage of the sum of all persons under 15 years and over 64 years divided by the number of persons age 15-64.

| Age-group | Population | Dependency ratio | |
|--------------------|------------|------------------|------------------------|
| 0-5 years | 520,812 | 29.1 | Young dependency ratio |
| 6-14 years | 911,378 | 51.0 | Young dependency ratio |
| 65 years and above | 177,278 | 9.9 | Old dependency ratio |

| | |
|---------------------------------|-----------|
| Total dependants (estimate) | 1,609,468 |
| Total non-dependants (estimate) | 1,788,047 |
| Gross Dependency Ratio | 90.0 |

5. Definitions

5.1 **Government schools** are schools administered and financed by the Ministry of Education.

5.2 **Non-government schools** are schools administered and financed by institutions other than the Ministry of Education.

5.2.1. **Domestic Community schools** are schools administered by municipalities or local committees.

5.2.2. **Foreign Community schools** are schools administered by foreign communities (Italian etc. communities).

5.2.3. **Awkaf (Mahad) schools** are schools administered by Awkaf (Islamic religion association).

5.2.4. **Mission schools** are schools administered by churches (Coptic, Catholic, and Protestant churches).

5.3 **Special schools** are schools for the deaf and the blind. There are two schools for the deaf, one in Keren and another in Asmera and one school for the blind in Asmera.

5.4 Number of schools by level:

A school having grades 1-11(12) is considered as three (1-5, 6-8, 9-12) schools by **level** regardless of being single **site**; another having grades 1-8 is considered as two schools as it contains two levels (1-5 and 6-8) etc.

5.5. Number of schools by site:

One single school compound or **site** may accommodate a combination of two or three level of schools but may be counted as one school **for purposes of specific location**. The number of schools by level is always greater than the number of schools by site.

III. Introductory information

Tables 1 and 2 give the number of students and teachers of general education, TTI and Technical and Vocational schools since 1991/92.

Table 1: Enrolment by level and gender 1991/92-2004/05

| Level | 1991/92 | | | 1992/93 | | | 1993/94 | | | 1994/95 | | | 1995/96 | | |
|------------------|----------------|---------------|----------------|----------------|----------------|----------------|----------------|----------------|----------------|----------------|----------------|----------------|----------------|----------------|----------------|
| | Male | Female | Total | Male | Female | Total | Male | Female | Total | Male | Female | Total | Male | Female | Total |
| Elementary level | 81,746 | 69,236 | 150,982 | 102,235 | 82,421 | 184,656 | 115,663 | 92,536 | 208,199 | 124,544 | 99,743 | 224,287 | 133,471 | 108,254 | 241,725 |
| Middle level | 14,414 | 13,503 | 27,917 | 15,052 | 13,375 | 28,427 | 18,129 | 14,652 | 32,781 | 19,310 | 15,685 | 34,995 | 21,648 | 18,103 | 39,751 |
| Secondary level | 14,444 | 13,183 | 27,627 | 17,141 | 14,390 | 31,531 | 19,432 | 13,324 | 32,756 | 22,097 | 14,631 | 36,728 | 23,676 | 15,475 | 39,151 |
| TTI | 978 | 290 | 1,268 | 1,860 | 720 | 2,580 | 344 | 54 | 398 | 1,511 | 674 | 2,185 | 84 | 9 | 93 |
| Tech. and voc. | 419 | 61 | 480 | 479 | 58 | 537 | 529 | 60 | 589 | 493 | 53 | 546 | 477 | 59 | 536 |
| Total | 112,001 | 96,273 | 208,274 | 136,767 | 110,964 | 247,731 | 154,097 | 120,626 | 274,723 | 167,955 | 130,786 | 298,741 | 179,356 | 141,900 | 321,256 |

| Level | 1996/97 | | | 1997/98 | | | 1998/99 | | | 1999/2000 | | | 2000/01 | | |
|------------------|----------------|----------------|----------------|----------------|----------------|----------------|----------------|----------------|----------------|----------------|----------------|----------------|----------------|----------------|----------------|
| | Male | Female | Total | Male | Female | Total | Male | Female | Total | Male | Female | Total | Male | Female | Total |
| Elementary level | 132,250 | 108,487 | 240,737 | 135,569 | 111,930 | 247,499 | 143,578 | 118,385 | 261,963 | 162,896 | 133,045 | 295,941 | 164,523 | 134,168 | 298,691 |
| Middle level | 26,739 | 20,721 | 47,460 | 32,998 | 24,154 | 57,152 | 37,731 | 29,290 | 67,021 | 41,033 | 33,284 | 74,317 | 41,457 | 35,107 | 76,564 |
| Secondary level | 24,262 | 16,332 | 40,594 | 25,198 | 16,417 | 41,615 | 29,777 | 17,756 | 47,533 | 37,533 | 22,093 | 59,626 | 40,355 | 23,596 | 63,951 |
| TTI | 307 | 52 | 359 | 391 | 87 | 478 | 398 | 73 | 471 | 477 | 129 | 606 | 764 | 197 | 961 |
| Tech. and voc. | 475 | 71 | 546 | 337 | 69 | 406 | 768 | 140 | 908 | 871 | 147 | 1,018 | 1,402 | 464 | 1,866 |
| Total | 184,033 | 145,663 | 329,696 | 194,493 | 152,657 | 347,150 | 212,252 | 165,644 | 377,896 | 242,810 | 188,698 | 431,508 | 248,501 | 193,532 | 442,033 |

| Level | 2001/02 | | | 2002/03 | | | 2003/04 | | | 2004/05 | | |
|------------------|----------------|----------------|----------------|----------------|----------------|----------------|----------------|----------------|----------------|----------------|----------------|----------------|
| | Male | Female | Total | Male | Female | Total | Male | Female | Total | Male | Female | Total |
| Elementary level | 184,060 | 146,218 | 330,278 | 199,860 | 159,563 | 359,423 | 209,043 | 165,954 | 374,997 | 210,061 | 167,451 | 377,512 |
| Middle level | 46,215 | 34,667 | 80,882 | 50,138 | 36,881 | 87,019 | 73,742 | 49,224 | 122,966 | 85,033 | 53,996 | 139,029 |
| Secondary level | 45,129 | 25,054 | 70,183 | 46,633 | 26,185 | 72,818 | 46,449 | 22,952 | 69,401 | 50,010 | 26,041 | 76,051 |
| TTI | 853 | 169 | 1,022 | 813 | 61 | 874 | 0 | 474 | 474 | 127 | 365 | 492 |
| Tech. and voc. | 1,599 | 393 | 1,992 | 1,536 | 429 | 1,965 | 1,386 | 531 | 1,917 | 1,827 | 675 | 1,152 |
| Total | 277,856 | 206,501 | 484,357 | 298,980 | 223,119 | 522,099 | 330,620 | 239,135 | 569,755 | 347,058 | 248,528 | 594,236 |

Table 2: Number of teachers by level and gender 1991/92-2004/05

| Level | 1991/92 | | | 1992/93 | | | 1993/94 | | | 1994/95 | | | 1995/96 | | |
|------------------|--------------|--------------|--------------|--------------|--------------|--------------|--------------|--------------|--------------|--------------|--------------|--------------|--------------|--------------|--------------|
| | Male | Female | Total | Male | Female | Total | Male | Female | Total | Male | Female | Total | Male | Female | Total |
| Elementary level | 2,236 | 1,411 | 3,647 | 3,113 | 1,841 | 4,954 | 3,407 | 1,865 | 5,272 | 3,609 | 1,974 | 5,583 | 3,803 | 2,025 | 5,828 |
| Middle level | 644 | 139 | 783 | 711 | 143 | 854 | 838 | 140 | 978 | 809 | 139 | 948 | 836 | 156 | 992 |
| Secondary level | 691 | 67 | 758 | 812 | 93 | 905 | 911 | 104 | 1,015 | 973 | 108 | 1,081 | 936 | 103 | 1,039 |
| TTI | 28 | 3 | 31 | 81 | 6 | 87 | 31 | 3 | 34 | 41 | 3 | 44 | 30 | 2 | 32 |
| Tech. and voc. | 62 | 5 | 67 | 71 | 4 | 75 | 63 | 0 | 63 | 72 | 2 | 74 | 74 | 6 | 80 |
| Total | 3,661 | 1,625 | 5,286 | 4,788 | 2,087 | 6,875 | 5,250 | 2,112 | 7,362 | 5,504 | 2,226 | 7,730 | 5,679 | 2,292 | 7,971 |

| Level | 1996/97 | | | 1997/98 | | | 1998/99 | | | 1999/2000 | | | 2000/01 | | |
|------------------|--------------|--------------|--------------|--------------|--------------|--------------|--------------|--------------|--------------|--------------|--------------|--------------|--------------|--------------|--------------|
| | Male | Female | Total | Male | Female | Total | Male | Female | Total | Male | Female | Total | Male | Female | Total |
| Elementary level | 3,499 | 1,977 | 5,476 | 3,906 | 1,893 | 5,799 | 3,625 | 1,951 | 5,576 | 3,899 | 2,330 | 6,229 | 3,958 | 2,710 | 6,668 |
| Middle level | 847 | 170 | 1,017 | 992 | 170 | 1,162 | 1,059 | 149 | 1,208 | 1,145 | 167 | 1,312 | 1,217 | 160 | 1,377 |
| Secondary level | 836 | 106 | 942 | 846 | 113 | 959 | 870 | 112 | 982 | 938 | 109 | 1,047 | 1,073 | 115 | 1,188 |
| TTI | 27 | 6 | 33 | 34 | 4 | 38 | 35 | 3 | 38 | 30 | 2 | 32 | 26 | 11 | 37 |
| Tech. and voc. | 78 | 1 | 79 | 66 | 0 | 66 | 97 | 4 | 101 | 95 | 9 | 104 | 164 | 9 | 173 |
| Total | 5,287 | 2,260 | 7,547 | 5,844 | 2,180 | 8,024 | 5,686 | 2,219 | 7,905 | 6,107 | 2,617 | 8,724 | 6,438 | 3,005 | 9,443 |

| Level | 2001/02 | | | 2002/03 | | | 2003/04 | | | 2004/05 | | |
|------------------|-------------|-------------|--------------|-------------|-------------|--------------|-------------|-------------|--------------|--------------|--------------|---------------|
| | Male | Female | Total | Male | Female | Total | Male | Female | Total | Male | Female | Total |
| Elementary level | 4625 | 2873 | 7498 | 4936 | 2756 | 7692 | 5146 | 2887 | 8033 | 4,776 | 3,166 | 7,942 |
| Middle level | 1352 | 177 | 1529 | 1436 | 178 | 1614 | 2025 | 216 | 2241 | 2,204 | 245 | 2,449 |
| Secondary level | 1274 | 145 | 1419 | 1137 | 140 | 1277 | 1430 | 215 | 1645 | 1,394 | 215 | 1,609 |
| TTI | 41 | 6 | 47 | 41 | 5 | 46 | 12 | 11 | 23 | 21 | 4 | 25 |
| Tech. and voc. | 157 | 17 | 174 | 196 | 69 | 265 | 248 | 78 | 326 | 153 | 16 | 169 |
| Total | 7449 | 3218 | 10667 | 7746 | 3148 | 10894 | 8861 | 3407 | 12268 | 8,548 | 3,646 | 12,194 |

Table 3. Non-government enrolment as percentage of total enrolment 1991/92 - 2004/05

| Year | Level | | | | | | | | |
|---------|----------|---------|------|----------|---------|------|----------|--------|-----|
| | 1- 5 | | | 6 - 7 | | | 8 - 11 | | |
| | Non Gov. | Total | % | Non Gov. | Total | % | Non Gov. | Total | % |
| 1991/92 | 33,377 | 150,870 | 22.1 | 4,788 | 27,917 | 17.2 | 794 | 27,627 | 2.9 |
| 1992/93 | 31,513 | 184,492 | 17.1 | 5,174 | 28,427 | 18.2 | 1,740 | 31,531 | 5.5 |
| 1993/94 | 31,766 | 208,199 | 15.3 | 5,203 | 32,781 | 15.9 | 1,984 | 32,756 | 6.1 |
| 1994/95 | 30,398 | 224,287 | 13.6 | 4,992 | 34,995 | 14.3 | 2,530 | 36,728 | 6.9 |
| 1995/96 | 30,650 | 241,725 | 12.7 | 5,385 | 39,751 | 13.5 | 3,514 | 39,151 | 9.0 |
| 1996/97 | 29,578 | 240,737 | 12.3 | 5,841 | 47,460 | 12.3 | 3,313 | 40,594 | 8.2 |
| 1997/98 | 27,292 | 247,499 | 11.0 | 5,401 | 57,152 | 9.5 | 2,634 | 41,615 | 6.3 |
| 1998/99 | 29,153 | 261,963 | 11.1 | 5,417 | 67,021 | 8.1 | 2,094 | 47,533 | 4.4 |
| 1999/00 | 29,766 | 295,941 | 10.1 | 5,155 | 74,317 | 6.9 | 2,292 | 59,626 | 3.8 |
| 2000/01 | 27,860 | 298,691 | 9.3 | 5,598 | 76,564 | 7.3 | 2,591 | 63,951 | 4.1 |
| 2001/02 | 27,269 | 330,278 | 8.3 | 5,758 | 80,882 | 7.1 | 2,672 | 70,183 | 3.8 |
| 2002/03 | 28,570 | 359,423 | 7.9 | 6,201 | 87,019 | 7.1 | 2,761 | 72,818 | 3.8 |
| | 1- 5 | | | 6 - 8 | | | 9-12 | | |
| 2003/04 | 29,134 | 374,997 | 7.8 | 8,933 | 122,966 | 7.3 | 2,630 | 69,401 | 3.8 |
| 2004/05 | 29,862 | 377,512 | 7.9 | 9,422 | 139,029 | 6.8 | 2,701 | 76,051 | 3.6 |

IV. Pre-primary level

1. Pre-primary schools

In 2004/05 there were 359 pre-primary schools in the whole country. 104 (29.0%) of them are located in Zoba Maekel. Out of which 41 (40%) are located in Asmara, the capital city.

In the academic year 2004/05 only 231 (64%) out of the 359 schools were government owned, while the rest of the schools, 128(35.6%) were non-government owned.

Table 4. Pre-primary: Location and ownership, 2004/05

| Region | Schools | | | | | | | | | | | | | | |
|----------------|---------|-----|-----|------------|-----|---------|-----|-------|-----|---------|-----|----------|-----|----------|-----|
| | Totals | | | Government | | Mission | | Awkaf | | Private | | DomComm. | | ForComm. | |
| | Tot | Urb | Rur | Urb | Rur | Urb | Rur | Urb | Rur | Urb | Rur | Urb | Rur | Urb | Rur |
| Anseba | 18 | 9 | 9 | 5 | 4 | 3 | 5 | | | | | 1 | | | |
| Deb Keih Bahri | 22 | 5 | 17 | 4 | 16 | 1 | 1 | | | | | | | | |
| Dehub | 104 | 22 | 82 | 7 | 42 | 6 | 8 | | | 3 | 3 | 6 | 29 | | |
| Gash Barka | 74 | 30 | 44 | 27 | 39 | 3 | 1 | | | | | | 4 | | |
| Maekel | 104 | 42 | 62 | 2 | 56 | 11 | 5 | 1 | | 5 | | 21 | 1 | 2 | |
| Sem Keih Bahri | 37 | 13 | 24 | 8 | 21 | 5 | 3 | | | | | | | | |
| Total | 359 | 121 | 238 | 53 | 178 | 29 | 23 | 1 | 0 | 8 | 3 | 28 | 34 | 2 | 0 |

N.B. Urb = Urban Rur = Rural Tot = Total DomComm= Domestic Community, ForComm = Foreign Community

2. Pre-primary enrolment

In this level, children of ages 5 and 6 are enrolled in pre-primary education. The gross enrolment ratio for the academic years 1991/92 and 2003/2004 were 4.3% and 9.1% respectively. But, in the academic year 2004/05 the gross enrolment ratios increased to 16.3%.

Table 5. Pre-primary age-group and gross enrolment ratio, 1991/92-2004/05

| Year | Population Age group 5-6. | | | Enrolment in pre-primary | | | Gross enrolment ratio | | |
|---------|------------------------------|--------|--------|--------------------------|-------|--------|-----------------------|------|--------|
| | Total | Male | Female | Total | Male | Female | Total | Male | Female |
| 1991/92 | 151758 | 80047 | 71711 | 6,461 | 3,142 | 3,319 | 4.26 | 3.93 | 4.63 |
| 1992/93 | 157155 | 83071 | 74084 | 7,031 | 3,426 | 3,605 | 4.47 | 4.12 | 4.87 |
| 1993/94 | 162451 | 85871 | 76580 | 7,748 | 3,909 | 3,839 | 4.77 | 4.55 | 5.01 |
| 1994/95 | 167681 | 88493 | 79188 | 8,032 | 4,102 | 3,930 | 4.79 | 4.64 | 4.96 |
| 1995/96 | 172869 | 90974 | 81895 | 8,180 | 4,201 | 3,979 | 4.73 | 4.62 | 4.86 |
| 1996/97 | 178026 | 93344 | 84682 | 7,443 | 3,791 | 3,652 | 4.18 | 4.06 | 4.31 |
| 1997/98 | 182438 | 95262 | 87176 | 9,300 | 4,683 | 4,617 | 5.10 | 4.92 | 5.30 |
| 1998/99 | 193506 | 100775 | 92731 | 11,581 | 6,168 | 5,413 | 5.98 | 6.12 | 5.84 |
| 1999/00 | 194782 | 101380 | 93402 | 11,885 | 6,181 | 5,704 | 6.10 | 6.10 | 6.11 |
| 2000/01 | 201401 | 104926 | 96475 | 12,436 | 6,540 | 5,896 | 6.17 | 6.23 | 6.11 |
| 2001/02 | 208703 | 108972 | 99731 | 12,747 | 6,704 | 6,043 | 6.11 | 6.15 | 5.55 |
| 2002/03 | 211624 | 110141 | 101483 | 14,958 | 7,563 | 7,395 | 7.07 | 6.87 | 7.29 |
| 2003/04 | 203602 | 106339 | 97263 | 18,540 | 9,821 | 8,719 | 9.11 | 9.24 | 8.96 |
| 2004/05 | 191368 | 91216 | 100152 | 31,244 | 15565 | 15,679 | 16.3 | 15.5 | 17.2 |

Table 6. Pre-primary age-group and net enrolment ratio in 1999/2000-2004/05

| Year | Population Age group 5-6. | | | Net enrolment in pre-primary | | | Net enrolment ratio | | |
|-----------|------------------------------|--------|--------|---------------------------------|--------|--------|---------------------|------|--------|
| | Total | Male | Female | Total | Male | Female | Total | Male | Female |
| 1999/2000 | 194782 | 101380 | 93402 | 9,471 | 4,907 | 4,564 | 4.86 | 4.84 | 4.89 |
| 2000/2001 | 201401 | 104926 | 96475 | 8,898 | 4,684 | 4,214 | 4.42 | 4.46 | 4.37 |
| 2001/2002 | 208703 | 108972 | 99731 | 9,160 | 4,828 | 4,332 | 4.39 | 4.43 | 4.34 |
| 2002/2003 | 211624 | 110141 | 101483 | 10,605 | 5,266 | 5,339 | 5.04 | 4.86 | 5.26 |
| 2003/2004 | 203602 | 106339 | 97263 | 13,189 | 6,826 | 6,363 | 6.48 | 6.42 | 6.54 |
| 2004/2005 | 191368 | 91216 | 100152 | 22,167 | 11,098 | 11,069 | 11.6 | 11.1 | 12.1 |

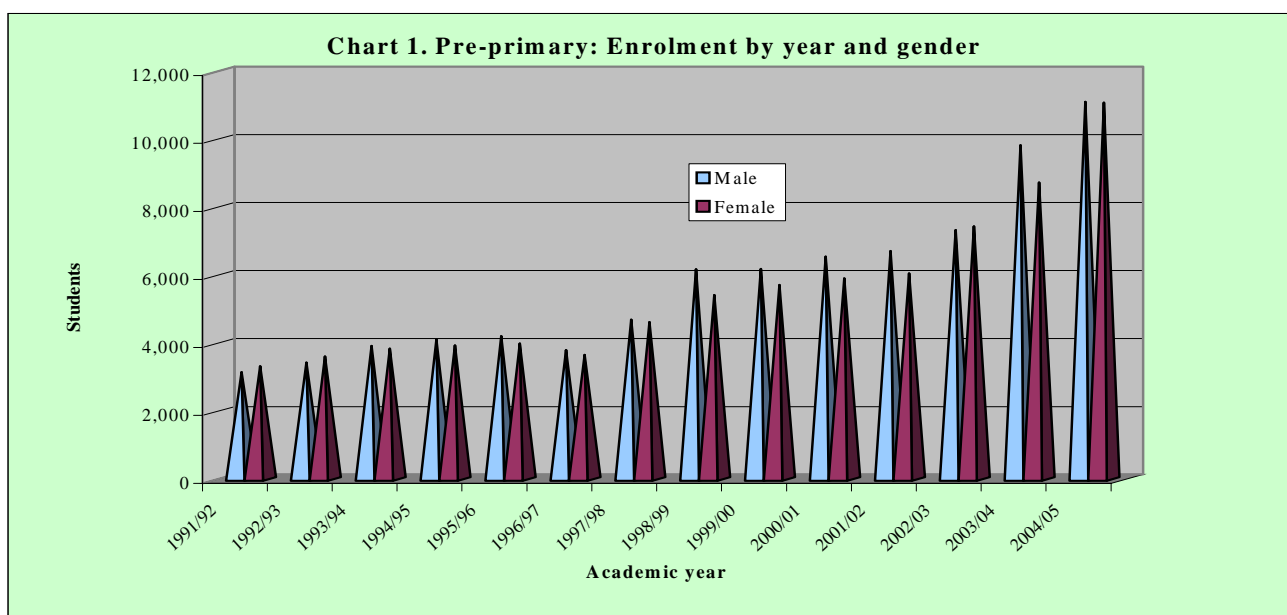

3. Pre-primary teachers

During the academic year 2004/2005 there were 845 pre-primary teachers in the whole country of whom 555 (65.7%) had professional training. 277 females and 13 male teachers were without any training. The number of teachers in pre-primary schools as seen in the following tables is very low. The opening of new pre-primary schools will therefore require training of new teachers.

As table 7 indicates almost all (816 which is 96.6%) teachers in pre-primary schools are females. In the academic year 1993/94 only one teacher, in 1995/96 other two male teachers and in 1998/99 other six male teachers joined the teaching force. In 2003/2004 the number of male teachers was only 21 and in 2004/05 the number of male teachers has increased by 8 while, the number of female teachers increased by 345.

Table 7. Pre-primary: Teachers and training status by region 2004/05

| Region | Total | | Trained | | Not trained | |
|----------------|------------|------------|------------|------------|-------------|------------|
| | Tot | F | Tot | F | Tot | F |
| Anseba | 71 | 61 | 34 | 26 | 37 | 35 |
| Deb-Keih-Bahri | 32 | 27 | 9 | 5 | 23 | 22 |
| Debub | 190 | 189 | 120 | 120 | 70 | 69 |
| Gash-Barka | 124 | 120 | 109 | 106 | 15 | 14 |
| Maekel | 357 | 348 | 246 | 245 | 111 | 103 |
| Sem-Keih-Bahri | 71 | 71 | 37 | 37 | 34 | 34 |
| Total | 845 | 816 | 555 | 539 | 290 | 277 |

**Table 8. Pre-primary: Pupil/teacher ratio
1991/92-2004/05**

| Year | Enrolment | | | Teachers | | | Pupil/teacher ratio |
|---------|-----------|--------|--------|----------|------|--------|---------------------|
| | Total | Male | Female | Total | Male | Female | |
| 1991/92 | 6,461 | 3,142 | 3,319 | 201 | 0 | 201 | 32 |
| 1992/93 | 7,031 | 3,426 | 3,605 | 227 | 0 | 227 | 31 |
| 1993/94 | 7,748 | 3,909 | 3,839 | 244 | 1 | 243 | 32 |
| 1994/95 | 8,032 | 4,102 | 3,930 | 256 | 1 | 255 | 31 |
| 1995/96 | 8,180 | 4,201 | 3,979 | 235 | 3 | 232 | 35 |
| 1996/97 | 7,443 | 3,791 | 3,652 | 207 | 3 | 204 | 36 |
| 1997/98 | 9,300 | 4,683 | 4,617 | 239 | 3 | 236 | 39 |
| 1998/99 | 11,581 | 6,168 | 5,413 | 321 | 9 | 312 | 36 |
| 1999/00 | 11,885 | 6,181 | 5,704 | 320 | 6 | 314 | 37 |
| 2000/01 | 12,436 | 6,540 | 5,896 | 326 | 8 | 318 | 38 |
| 2001/02 | 12,747 | 6,704 | 6,043 | 353 | 6 | 347 | 37 |
| 2002/03 | 14,958 | 7,563 | 7,395 | 410 | 19 | 391 | 37 |
| 2003/04 | 18,540 | 9,821 | 8,719 | 492 | 21 | 471 | 38 |
| 2004/05 | 31,244 | 15,565 | 15,679 | 845 | 29 | 816 | 37 |

Table 9. Pre-primary Percentage of female teachers 1991/92-2004/05

| Year | Teachers | | | Percentage of female teachers |
|---------|----------|--------|-------|-------------------------------|
| | Male | Female | Total | |
| 1991/92 | 0 | 201 | 201 | 100.0 |
| 1992/93 | 0 | 227 | 227 | 100.0 |
| 1993/94 | 1 | 243 | 244 | 99.6 |
| 1994/95 | 1 | 255 | 256 | 99.6 |
| 1995/96 | 3 | 232 | 235 | 98.7 |
| 1996/97 | 3 | 204 | 207 | 98.6 |
| 1997/98 | 3 | 236 | 239 | 98.7 |
| 1998/99 | 9 | 312 | 321 | 97.2 |
| 1999/00 | 6 | 314 | 320 | 98.1 |
| 2000/01 | 8 | 318 | 326 | 97.5 |
| 2001/02 | 6 | 347 | 353 | 98.3 |
| 2002/03 | 19 | 394 | 413 | 95.4 |
| 2003/04 | 21 | 471 | 492 | 95.7 |
| 2004/05 | 29 | 816 | 845 | 96.6 |

V. Elementary level

1. Duration

In this level children of ages 7-11 are enrolled from grades 1-5. Education in this level is free and compulsory.

Starting from 1991/92 academic year enrolment at the elementary level has been steadily increasing. At this level, Medium of instruction is the mother tongue.

2. Enrolment

Enrolment in this level for the year 2004/2005 was 377,512 out of which 167,451 (44.4%) were females. Out of the total enrolment in elementary schools, 347,650 (7.9%) were enrolled in non-government schools.

Table 10. Elementary level: Enrolment by Region and gender 2004/05

| Region | Total | Male | Female |
|----------------|---------------|---------------|---------------|
| Anseba | 54212 | 30629 | 23583 |
| Deb-Keih-Bahri | 4892 | 3347 | 1545 |
| Debab | 135419 | 73283 | 62136 |
| Gash-Barka | 79544 | 46247 | 33297 |
| Maekel | 73825 | 38504 | 35321 |
| Sem-Keih-Bahri | 29620 | 18051 | 11569 |
| Total | 377512 | 210061 | 167451 |

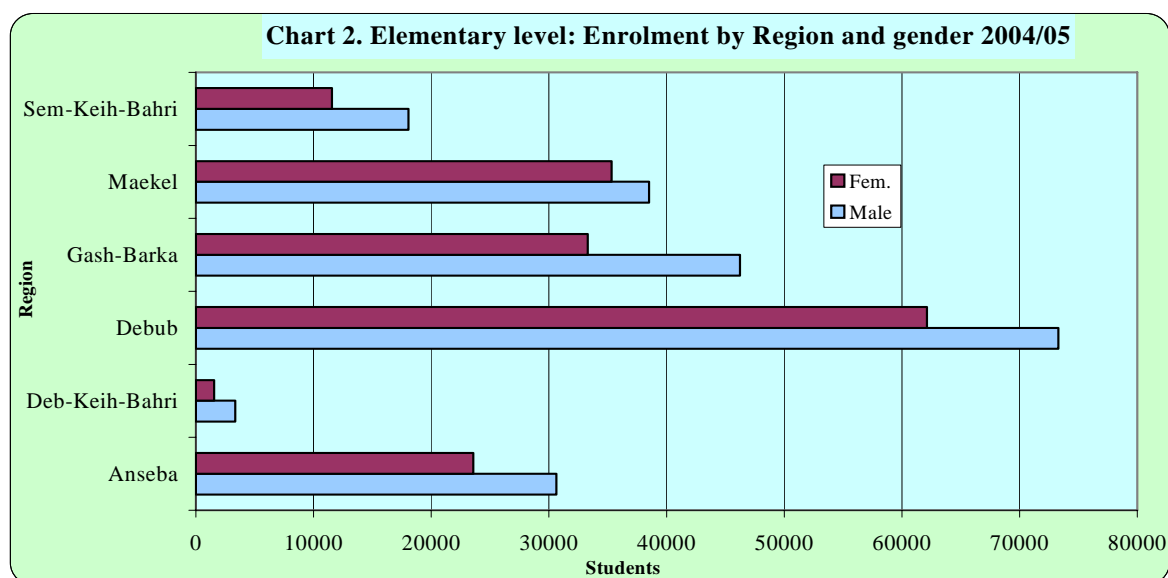

3. Gross admission ratio

Table 11. Elementary level: Gross admission ratio 1991/92-2004/05

| Year | Population of age 7 | | | Admission in grade 1 | | | Gross admission ratio | | |
|---------|---------------------|--------|--------|----------------------|--------|--------|-----------------------|-------|--------|
| | Total | Male | Female | Total | Male | Female | Total | Male | Female |
| 1991/92 | 76,409 | 40,250 | 36,159 | 46,671 | 25,807 | 20,864 | 61.08 | 64.12 | 57.70 |
| 1992/93 | 79,125 | 41,770 | 37,355 | 46,210 | 26,612 | 19,598 | 58.40 | 63.71 | 52.46 |
| 1993/94 | 81,793 | 43,179 | 38,614 | 45,656 | 25,432 | 20,224 | 55.82 | 58.90 | 52.37 |
| 1994/95 | 84,426 | 44,497 | 39,929 | 44,285 | 24,159 | 20,126 | 52.45 | 54.29 | 50.40 |
| 1995/96 | 87,038 | 45,745 | 41,293 | 46,497 | 26,108 | 20,389 | 53.42 | 57.07 | 49.38 |
| 1996/97 | 89,635 | 46,937 | 42,698 | 41,122 | 22,578 | 18,544 | 45.88 | 48.10 | 43.43 |
| 1997/98 | 91,857 | 47,901 | 43,956 | 50,471 | 28,407 | 22,064 | 54.95 | 59.30 | 50.20 |
| 1998/99 | 97,430 | 50,673 | 46,757 | 57,336 | 31,758 | 25,578 | 58.85 | 62.67 | 54.70 |
| 1999/00 | 98,147 | 50,689 | 47,458 | 68,902 | 38,345 | 30,557 | 70.20 | 75.65 | 64.39 |
| 2000/01 | 101,482 | 52,462 | 49,020 | 72,139 | 39,595 | 32,544 | 71.09 | 75.47 | 66.39 |
| 2001/02 | 105,158 | 54,484 | 50,674 | 74,899 | 41,114 | 33,785 | 71.23 | 75.46 | 66.67 |
| 2002/03 | 106,633 | 55,069 | 51,564 | 76,145 | 41,767 | 34,378 | 71.41 | 75.84 | 66.67 |
| 2003/04 | 103,616 | 52,494 | 51,122 | 68,983 | 38,059 | 30,924 | 66.57 | 72.50 | 60.49 |
| 2004/05 | 102,181 | 53,250 | 48,931 | 69,166 | 37,633 | 31,533 | 67.68 | 70.67 | 64.44 |

As can be noted in Table 11, the gross admission ratio dropped continuously from 61.08% to 45.88% between 1991/92 and 1996/97 (except for 1995/96 academic year). The gross admission ratio started to increase from 1997/98 and reached 71.41 in 2002/2003 and dropped to 66.57, and 67.68 in 2003/04 and 2004/05 respectively.

4. Net admission ratio

Table 12. Elementary level: Net admission ratios 1991/92-2004/05

| Year | Population (7-year-old) | | | New entrants (7-year-old) | | | Net admission ratio (NAR) | | |
|---------|------------------------------|--------|--------|------------------------------|--------|--------|--------------------------------|-------|-------|
| | T | M | F | T | M | F | T | M | F |
| 1991/92 | 76,409 | 40,250 | 36,159 | 8,605 | 4,580 | 4,025 | 11.26 | 11.38 | 11.13 |
| 1992/93 | 79,125 | 41,770 | 37,355 | N.A | NA | NA | N.A | NA | NA |
| 1993/94 | 81,793 | 43,179 | 38,614 | 9,947 | 5,392 | 4,555 | 12.16 | 12.49 | 11.80 |
| 1994/95 | 84,426 | 44,497 | 39,929 | 11,227 | 5,949 | 5,278 | 13.30 | 13.37 | 13.22 |
| 1995/96 | 87,038 | 45,745 | 41,293 | 15,612 | 8,053 | 7,559 | 17.94 | 17.60 | 18.31 |
| 1996/97 | 89,635 | 46,937 | 42,698 | 15,469 | 8,132 | 7,337 | 17.26 | 17.33 | 17.18 |
| 1997/98 | 91,857 | 47,901 | 43,956 | 14,370 | 7,723 | 6,647 | 15.64 | 16.12 | 15.12 |
| 1998/99 | 97,430 | 50,673 | 46,757 | 18,140 | 9,608 | 8,532 | 18.62 | 18.96 | 18.25 |
| 1999/00 | 98,147 | 50,689 | 47,458 | 20,674 | 11,169 | 9,505 | 21.06 | 22.03 | 20.03 |
| 2000/01 | 101,482 | 52,462 | 49,020 | 32,977 | 17,632 | 15,345 | 32.50 | 33.61 | 31.30 |
| 2001/02 | 105,158 | 54,484 | 50,674 | 37,071 | 20,094 | 16,977 | 35.25 | 36.88 | 33.50 |
| 2002/03 | 106,633 | 55,069 | 51,564 | 33,199 | 17,810 | 15,389 | 31.13 | 32.34 | 30.66 |
| 2003/04 | 103,616 | 52,494 | 51,122 | 29,568 | 15,906 | 13,662 | 28.54 | 30.30 | 26.72 |
| 2004/05 | 102,181 | 53,250 | 48,931 | 47,429 | 25,008 | 22,421 | 46.41 | 46.96 | 45.82 |

Unlike the gross admission ratio, the net admission ratio has increased yearly between the successive academic years of 1991/92-2001/02 except in 1997/98, and in the academic year 2002/03 and 2003/04 it has shown a decrease of 4% and 3% respectively, while in the academic year 2004/05 it increased by about 12%.

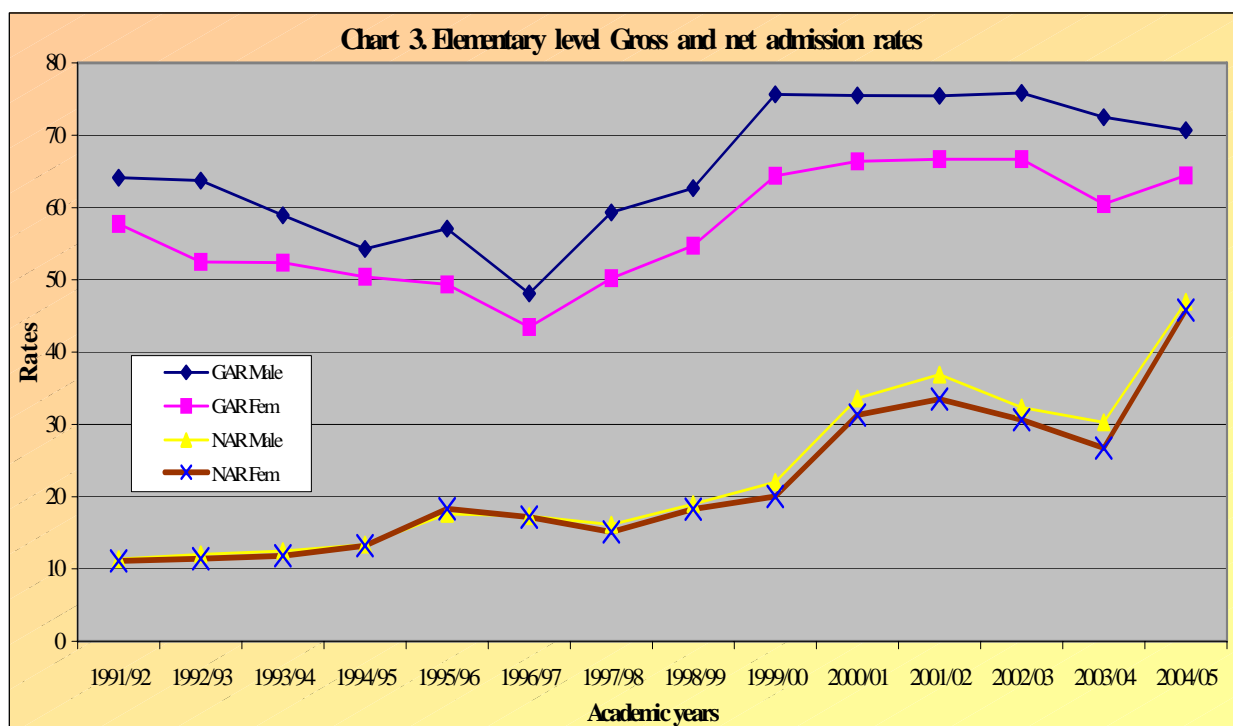

5. Over-age pupils in grade 1.

Table 13. Elementary level: Enrolment and percentage of over-age pupils in grade 1, 1991/92-2004/05

| Year | Enrolment in grade 1 | | | Over-age enrolment in grade 1 | | | Percentage of over-age in grade 1 | | |
|---------|----------------------|--------|--------|-------------------------------|--------|--------|-----------------------------------|------|--------|
| | Total | Male | Female | Total | Male | Female | Total | Male | Female |
| 1991/92 | 67,550 | 36,867 | 30,683 | 52,427 | 28,919 | 23,508 | 77.6 | 78.4 | 76.6 |
| 1992/93 | 68,770 | 38,291 | 30,479 | N.A | NA | NA | NA | NA | NA |
| 1993/94 | 64,527 | 35,101 | 29,426 | 48,963 | 26,886 | 22,075 | 75.9 | 76.6 | 75.0 |
| 1994/95 | 62,914 | 33,793 | 29,121 | 46,192 | 25,043 | 21,147 | 73.4 | 74.1 | 72.6 |
| 1995/96 | 65,110 | 34,869 | 30,241 | 47,320 | 25,600 | 21,718 | 72.7 | 73.4 | 71.8 |
| 1996/97 | 58,841 | 31,820 | 27,021 | 40,404 | 22,032 | 18,372 | 68.7 | 69.2 | 68.0 |
| 1997/98 | 68,388 | 38,104 | 30,284 | 48,649 | 27,496 | 21,153 | 71.1 | 72.2 | 69.8 |
| 1998/99 | 75,340 | 41,586 | 33,754 | 50,409 | 28,365 | 22,044 | 66.9 | 68.2 | 65.3 |
| 1999/00 | 91,037 | 50,459 | 40,576 | 59,351 | 33,493 | 25,858 | 65.2 | 66.4 | 63.7 |
| 2000/01 | 88,045 | 47,907 | 40,138 | 45,357 | 25,146 | 20,211 | 51.5 | 52.5 | 50.4 |
| 2001/02 | 97,678 | 53,409 | 44,269 | 48,885 | 27,137 | 21,748 | 50.0 | 50.9 | 49.1 |
| 2002/03 | 101,496 | 55,186 | 46,310 | 53,456 | 28,270 | 25,186 | 52.7 | 51.2 | 54.4 |
| 2003/04 | 99,216 | 54,309 | 44,907 | 46,542 | 26,229 | 20,313 | 46.9 | 48.3 | 45.2 |
| 2004/05 | 89,524 | 48,902 | 40,622 | 36,585 | 20,831 | 15,754 | 40.9 | 42.6 | 38.78 |

N.B. NA = not available

Table 13 indicates that the percentage of over-age pupils has been decreasing every academic year, except for the 1997/98 and 2002/03 academic years. In the academic year 2003/04 and 2004/05 the percentage of over-age students in grade 1 was 46.9 and 40.9 percent respectively. Although progress has been made in decreasing over age students more effort is needed to overcome this challenge.

6. Under-age pupils in grade 1

Table 14. Elementary level: Enrolment and percentage of under-age pupils in grade 1 1991/92-2004/05

| Year | Enrolment in Grade 1 | | | Under-age enrolment in grade | | | Percentage of under-age | | |
|---------|----------------------|--------|--------|------------------------------|-------|--------|-------------------------|------|--------|
| | Tot | Male | Female | Tot | Male | Female | Tot | Male | Female |
| 1991/92 | 67,550 | 36,867 | 30,683 | 2,661 | 1,405 | 1,256 | 3.9 | 3.8 | 4.1 |
| 1992/93 | 68,770 | 38,291 | 30,479 | 1,906 | 962 | 944 | 2.8 | 2.5 | 3.1 |
| 1993/94 | 64,527 | 35,101 | 29,426 | 1,527 | 778 | 749 | 2.3 | 2.2 | 2.5 |
| 1994/95 | 62,914 | 33,793 | 29,121 | 865 | 447 | 418 | 1.4 | 1.3 | 1.4 |
| 1995/96 | 65,110 | 34,869 | 30,241 | 880 | 445 | 435 | 1.4 | 1.3 | 1.4 |
| 1996/97 | 58,841 | 31,820 | 27,021 | 1,135 | 588 | 547 | 1.9 | 1.8 | 2.0 |
| 1997/98 | 68,388 | 38,104 | 30,284 | 1,186 | 637 | 549 | 1.7 | 1.7 | 1.8 |
| 1998/99 | 75,340 | 41,586 | 33,754 | 3,497 | 1,814 | 1,683 | 4.6 | 4.4 | 5.0 |
| 1999/00 | 91,037 | 50,459 | 40,576 | 6,295 | 3,294 | 3,001 | 6.9 | 6.5 | 7.4 |
| 2000/01 | 88,045 | 47,907 | 40,138 | 9,693 | 5,112 | 4,581 | 11.0 | 10.7 | 11.4 |
| 2001/02 | 97,678 | 53,409 | 44,269 | 11,722 | 6,178 | 5,544 | 12.0 | 11.6 | 12.5 |
| 2002/03 | 101,496 | 55,186 | 46,310 | 10,990 | 5,704 | 5,286 | 10.8 | 10.3 | 11.4 |
| 2003/04 | 99,216 | 54,309 | 44,907 | 13,682 | 7,062 | 6,620 | 13.8 | 13.0 | 14.7 |
| 2004/05 | 89,524 | 48,902 | 40,622 | 15,520 | 8,090 | 7,430 | 17.3 | 16.5 | 18.3 |

From the academic year 1991/92 until the academic year 1997/98 except for the academic year 1996/97 enrolment of under-age was continuously decreasing. This was mainly because MOE regulations in those years did not allow children under 7 to be enrolled in elementary schools. Starting from the year 1997/98 the enrolment of under-age children increased continuously. This development could be explained by the ministry's apparent permission to register children of 6 years of age.

7. Children out of school

Table 15. Net enrolment and children out of school 1991/92-2004/05

| Academic Year | Population 7-11. | | | Net enrolment 7-11. | | | NER | Number of children out of school 7-11 | | | Percentage of children out of School 7-11 |
|---------------|------------------|---------|---------|---------------------|---------|---------|-------|---------------------------------------|---------|---------|---|
| | T | M | F | T | M | F | | T | M | F | |
| 1991/92 | 375,234 | 198,552 | 176,682 | 93,087 | 48,397 | 44,690 | 24.81 | 282,147 | 150,155 | 131,992 | 75.19 |
| 1992/93 | 388,581 | 206,052 | 182,529 | 109,111 | 57,126 | 51,985 | 28.08 | 279,470 | 148,926 | 130,544 | 71.92 |
| 1993/94 | 401,679 | 213,000 | 188,679 | 113,612 | 59,645 | 53,967 | 28.28 | 288,067 | 153,355 | 134,712 | 71.72 |
| 1994/95 | 414,606 | 219,502 | 195,104 | 122,084 | 64,098 | 57,986 | 29.45 | 292,522 | 155,404 | 137,118 | 70.55 |
| 1995/96 | 427,429 | 225,658 | 201,771 | 133,496 | 69,958 | 63,538 | 31.23 | 293,933 | 155,700 | 138,233 | 68.77 |
| 1996/97 | 440,171 | 231,537 | 208,634 | 136,943 | 72,073 | 64,870 | 31.11 | 303,228 | 159,464 | 143,764 | 68.89 |
| 1997/98 | 451,076 | 236,293 | 214,783 | 150,751 | 80,212 | 70,539 | 33.42 | 300,325 | 156,081 | 144,244 | 66.58 |
| 1998/99 | 478,441 | 249,970 | 228,471 | 166,879 | 89,556 | 77,323 | 34.88 | 311,562 | 160,414 | 151,148 | 65.12 |
| 1999/00 | 470,652 | 239,841 | 230,811 | 194,963 | 104,748 | 90,215 | 41.42 | 275,689 | 135,093 | 140,596 | 58.58 |
| 2000/01 | 486,639 | 248,232 | 238,407 | 205,831 | 111,022 | 94,809 | 42.30 | 280,808 | 137,210 | 143,598 | 57.70 |
| 2001/02 | 504,246 | 257,793 | 246,453 | 232,030 | 125,941 | 106,089 | 46.02 | 272,216 | 131,852 | 140,364 | 53.98 |
| 2002/03 | 511,350 | 260,568 | 250,782 | 256,360 | 139,072 | 117,288 | 50.13 | 255,012 | 121,510 | 133,502 | 49.87 |
| 2003/04 | 522,975 | 268,340 | 254,635 | 269,326 | 146,379 | 122,947 | 51.50 | 250,252 | 120,296 | 129,956 | 47.86 |
| 2004/05 | 526,266 | 271,547 | 254,719 | 276,815 | 149,916 | 126,899 | 52.60 | 245,439 | 119,584 | 125,855 | 46.63 |

Chart 4. Elementary level: Enrolment by year and gender

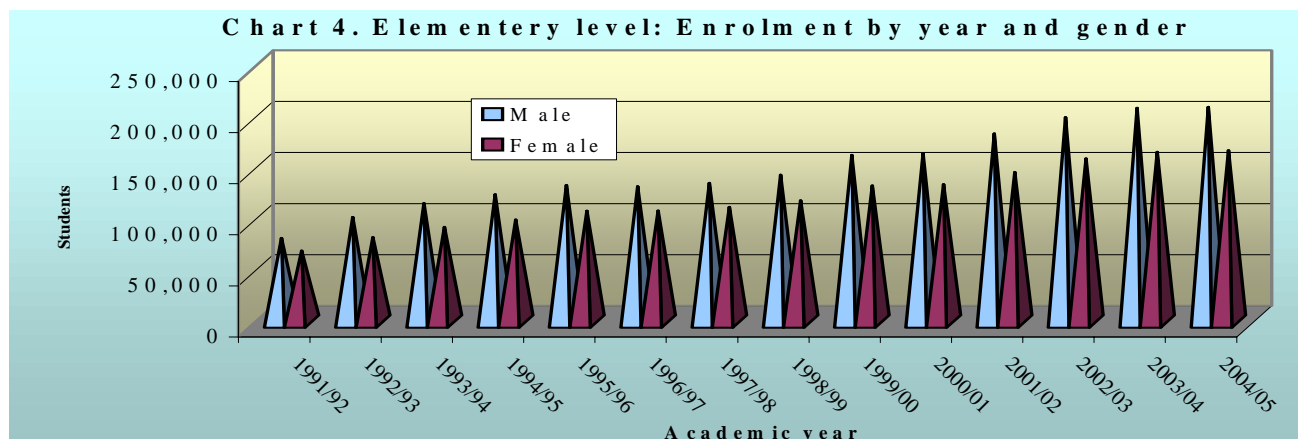

8. Gross enrolment ratio, elementary level

Table 16. Elementary level: Gross enrolment ratio 1991/92-2004/05

| Academic Year | Total Population 7-11 | | | Enrolment in elementary level | | | Gross enrolment ratio | | |
|---------------|-----------------------|---------|---------|-------------------------------|---------|---------|-----------------------|-------|-------|
| | T | M | F | T | M | F | T | M | F |
| 1991/92 | 375,234 | 198,552 | 176,682 | 150,982 | 81,746 | 69,236 | 40.24 | 41.17 | 39.19 |
| 1992/93 | 388,581 | 206,052 | 182,529 | 184,656 | 102,235 | 82,421 | 47.52 | 49.62 | 45.16 |
| 1993/94 | 401,679 | 213,000 | 188,679 | 208,199 | 115,663 | 92,536 | 51.83 | 54.30 | 49.04 |
| 1994/95 | 414,606 | 219,502 | 195,104 | 224,287 | 124,544 | 99,743 | 54.10 | 56.74 | 51.12 |
| 1995/96 | 427,429 | 225,658 | 201,771 | 241,725 | 133,471 | 108,254 | 56.55 | 59.15 | 53.65 |
| 1996/97 | 440,171 | 231,537 | 208,634 | 240,737 | 132,250 | 108,487 | 54.69 | 57.12 | 52.00 |
| 1997/98 | 451,076 | 236,293 | 214,783 | 247,499 | 135,569 | 111,930 | 54.87 | 57.37 | 52.11 |
| 1998/99 | 478,441 | 249,970 | 228,471 | 261,963 | 143,578 | 118,385 | 54.75 | 57.44 | 51.82 |
| 1999/00 | 470,652 | 239,841 | 230,811 | 295,941 | 162,896 | 133,045 | 62.88 | 67.92 | 57.64 |
| 2000/01 | 486,639 | 248,232 | 238,407 | 298,691 | 164,523 | 134,168 | 61.38 | 66.28 | 56.28 |
| 2001/02 | 504,246 | 257,793 | 246,453 | 330,278 | 184,060 | 146,218 | 65.50 | 71.40 | 59.33 |
| 2002/03 | 511,350 | 260,568 | 250,782 | 359,423 | 199,860 | 159,563 | 70.28 | 76.69 | 63.62 |
| 2003/04 | 522,975 | 268,340 | 254,635 | 374,997 | 209,043 | 165,954 | 71.70 | 77.90 | 65.17 |
| 2004/05 | 526,266 | 271,547 | 254,719 | 377,512 | 210,061 | 167,451 | 71.73 | 77.36 | 65.74 |

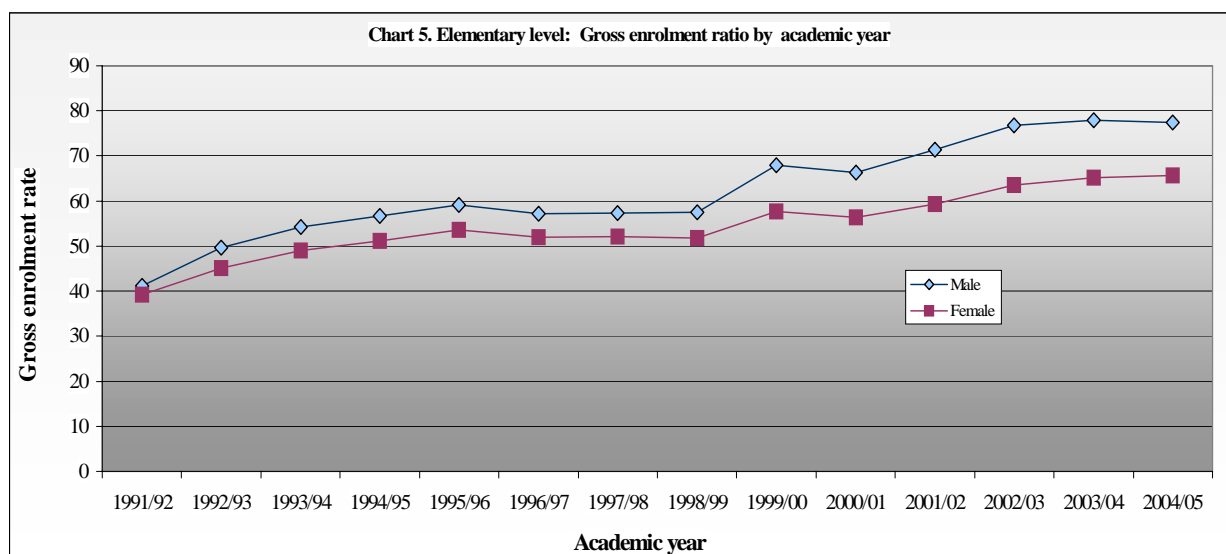

9. Net enrolment ratio

Table 17. Elementary level: Net enrolment and net enrolment ratio: 1991/92-2004/05

| Academic Year | Population age 7-11. | | | Net enrolment in elementary level | | | Net enrolment ratio % | | |
|---------------|----------------------|---------|---------|-----------------------------------|---------|---------|-----------------------|-------|-------|
| | T | M | F | T | M | F | T | M | F |
| 1991/92 | 375,234 | 198,552 | 176,682 | 93,087 | 48,397 | 44,690 | 24.81 | 24.37 | 25.29 |
| 1992/93 | 388,581 | 206,052 | 182,529 | 109,111 | 57,126 | 51,985 | 28.08 | 27.72 | 28.48 |
| 1993/94 | 401,679 | 213,000 | 188,679 | 113,612 | 59,645 | 53,967 | 28.28 | 28.00 | 28.60 |
| 1994/95 | 414,606 | 219,502 | 195,104 | 122,084 | 64,098 | 57,986 | 29.45 | 29.20 | 29.72 |
| 1995/96 | 427,429 | 225,658 | 201,771 | 133,496 | 69,958 | 63,538 | 31.23 | 31.00 | 31.49 |
| 1996/97 | 440,171 | 231,537 | 208,634 | 136,943 | 72,073 | 64,870 | 31.11 | 31.13 | 31.09 |
| 1997/98 | 451,076 | 236,293 | 214,783 | 150,751 | 80,212 | 70,539 | 33.42 | 33.95 | 32.84 |
| 1998/99 | 478,441 | 249,970 | 228,471 | 166,879 | 89,556 | 77,323 | 34.88 | 35.83 | 33.84 |
| 1999/00 | 470,652 | 239,841 | 230,811 | 194,963 | 104,743 | 90,215 | 41.42 | 43.67 | 39.09 |
| 2000/01 | 486,639 | 248,232 | 238,407 | 205,831 | 111,022 | 94,809 | 42.30 | 44.73 | 39.77 |
| 2001/02 | 504,246 | 257,793 | 246,453 | 232,030 | 125,941 | 106,089 | 46.02 | 48.85 | 43.05 |
| 2002/03 | 511,350 | 260,568 | 250,782 | 256,360 | 139,072 | 117,288 | 50.13 | 53.37 | 46.77 |
| 2003/04 | 522,975 | 268,340 | 254,635 | 269,326 | 146,379 | 122,947 | 51.50 | 54.55 | 48.28 |
| 2004/05 | 526,266 | 271,547 | 254,719 | 276,815 | 149,916 | 126,899 | 52.60 | 55.21 | 49.82 |

10. Disparities among regions

Table 18. Elementary level: Gross enrolment ratio by region 2004/05

| Region | Population age 7-11 | Gross enrolment | Gross enrolment ratio | Deviation from national ratio |
|----------------|---------------------|-----------------|-----------------------|-------------------------------|
| Anseba | 74,795 | 54,212 | 72.5 | 0.8 |
| Deb-Keih-Bahri | 11,254 | 4,892 | 43.5 | -28.2 |
| Debab | 132,806 | 135,419 | 102.0 | 30.3 |
| Gash Barka | 123,552 | 79,544 | 64.4 | -7.3 |
| Maekel | 95,260 | 73,825 | 77.5 | 5.8 |
| Sem-Keih-Bahri | 88,599 | 29,620 | 33.4 | -38.3 |
| Total | 526,266 | 377,512 | 71.7 | 0.0 |

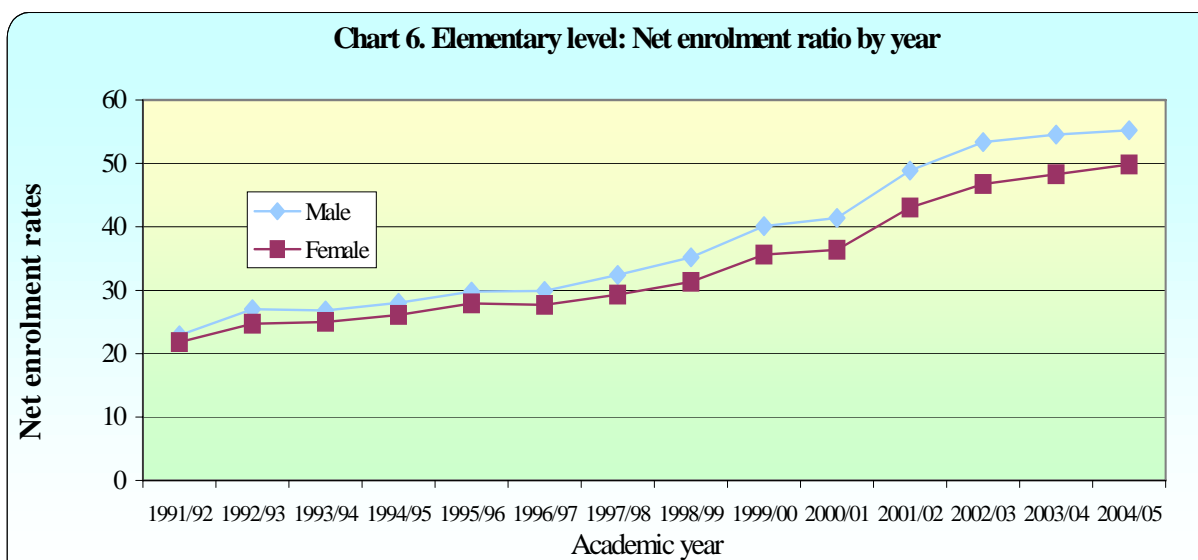
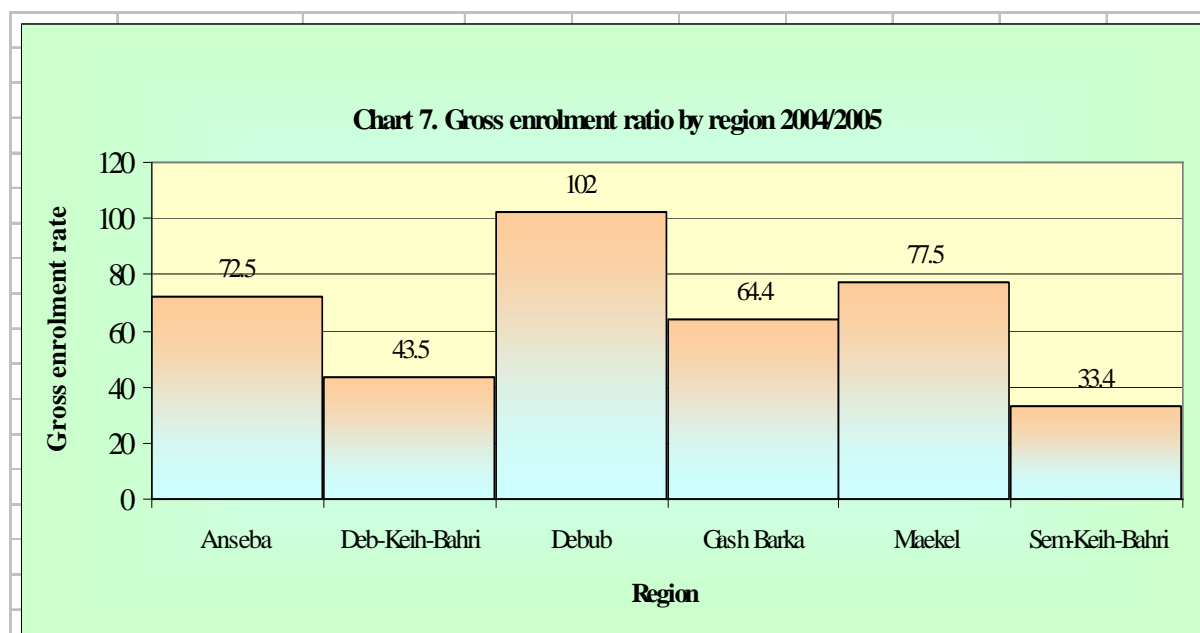

Table 19. Elementary level: Net enrolment ratio by region 2004/05

| Region | Population age 7-11 | Net enrolment | Net enrolment ratio | Deviation from national ratio |
|----------------|---------------------|----------------|---------------------|-------------------------------|
| Anseba | 74,795 | 40,050 | 53.5 | 0.9 |
| Deb-Keih-Bahri | 11,254 | 3,170 | 28.2 | -24.4 |
| Debub | 132,806 | 101,101 | 76.1 | 23.5 |
| Gash-Barka | 123,552 | 55,043 | 44.6 | -8.0 |
| Maekel | 95,260 | 55,464 | 58.2 | 5.6 |
| Sem-Keih-Bahri | 88,599 | 21,987 | 24.8 | -27.8 |
| Total | 526,266 | 276,815 | 52.6 | 0.0 |



VI. Middle level

1. Duration

The duration of Middle level is three years (grade 6, 7 and 8). It is the second level of the compulsory basic education. English is the medium of instruction in this level. School age for this level is from 12-14.

2. Enrolment

Enrolment in this level for the academic year 2004/05 was 139,029. Female enrolment constitute 53,996 (38.8%) of the total number. Non-government enrolment in this level is 9,422 (6.8%).

**Table 20. Middle level: Enrolment by grade, gender and Region
2004/05
(Government and non-government)**

| Region | Totals 6-8 | | | Grade 6 | | | Grade 7 | | | Grade 8 | | |
|----------------|---------------|--------------|--------------|--------------|--------------|--------------|--------------|--------------|--------------|--------------|--------------|--------------|
| | Totals | Male | Female | Total | Male | Female | Total | Male | Female | Total | Male | Female |
| Anseba | 17463 | 11278 | 6185 | 7310 | 4740 | 2570 | 5536 | 3548 | 1988 | 4617 | 2990 | 1627 |
| Deb-Keih-Bahri | 1742 | 1343 | 399 | 643 | 495 | 148 | 525 | 406 | 119 | 574 | 442 | 132 |
| Debub | 45406 | 28709 | 16697 | 18224 | 11127 | 7097 | 14425 | 9211 | 5214 | 12757 | 8371 | 4386 |
| Gash-Barka | 18137 | 12483 | 5654 | 8380 | 5795 | 2585 | 5245 | 3573 | 1672 | 4512 | 3115 | 1397 |
| Maekel | 46036 | 23670 | 22366 | 14444 | 7551 | 6893 | 14904 | 7592 | 7312 | 16688 | 8527 | 8161 |
| Sem-Keih-Bahri | 10245 | 7550 | 2695 | 4472 | 3245 | 1227 | 3191 | 2382 | 809 | 2582 | 1923 | 659 |
| Totals | 139029 | 85033 | 53996 | 53473 | 32953 | 20520 | 43826 | 26712 | 17114 | 41730 | 25368 | 16362 |

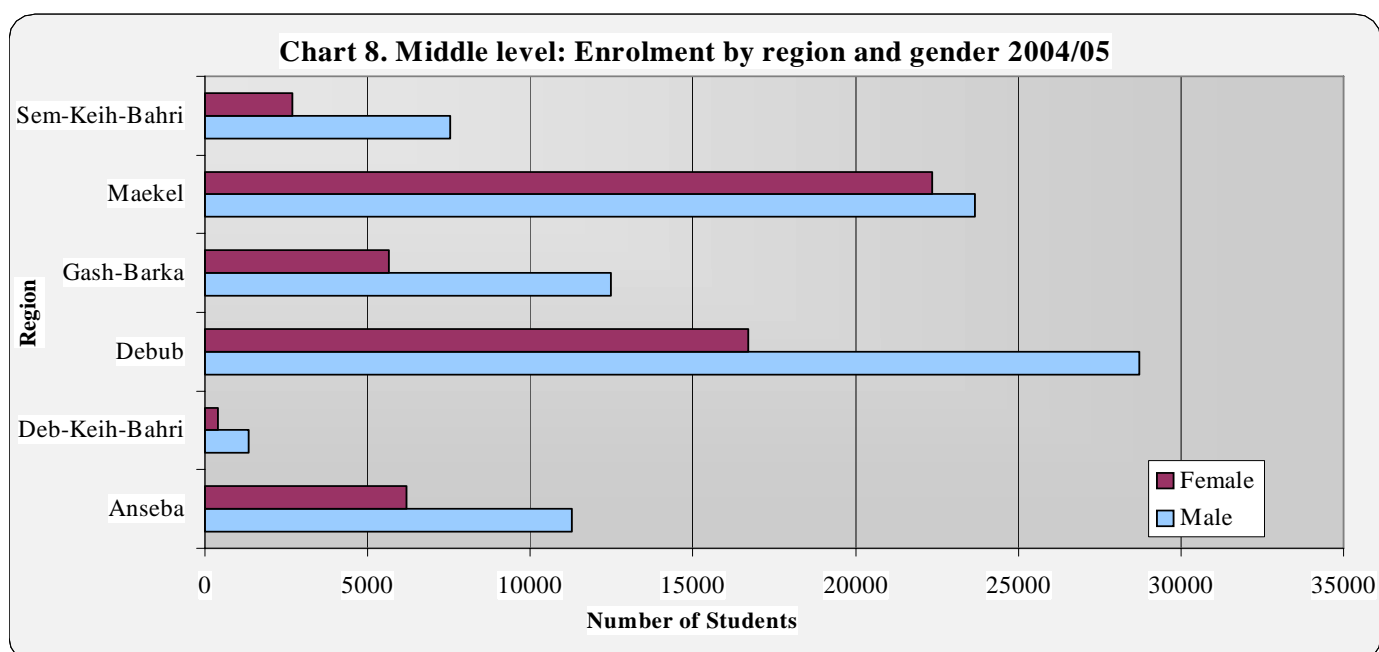

3. Gross enrolment ratio

Table 21. Middle level: Gross Enrolment Ratio 1991/92-2004/05

| Year | Population 12-13 | | | Enrolment | | | Gross enrolment ratio | | |
|---------|-------------------------|---------|---------|-----------|--------|--------|-----------------------|-------|--------|
| | Total | Male | Female | Total | Male | Female | Total | Male | Female |
| 1991/92 | 136,712 | 72,904 | 63,808 | 27,917 | 14,414 | 13,503 | 20.42 | 19.77 | 21.16 |
| 1992/93 | 141,576 | 75,657 | 65,919 | 28,431 | 15,052 | 13,379 | 20.08 | 19.90 | 20.30 |
| 1993/94 | 146,349 | 78,209 | 68,140 | 32,781 | 18,129 | 14,652 | 22.40 | 23.18 | 21.50 |
| 1994/95 | 151,058 | 80,597 | 70,461 | 34,995 | 19,310 | 15,685 | 23.17 | 23.96 | 22.26 |
| 1995/96 | 155,725 | 82,856 | 72,869 | 39,751 | 21,648 | 18,103 | 25.53 | 26.13 | 24.84 |
| 1996/97 | 160,363 | 85,015 | 75,348 | 47,460 | 26,739 | 20,721 | 29.60 | 31.45 | 27.50 |
| 1997/98 | 164,331 | 86,762 | 77,569 | 57,152 | 32,998 | 24,154 | 34.78 | 38.03 | 31.14 |
| 1998/99 | 174,295 | 91,783 | 82,512 | 67,021 | 37,731 | 29,290 | 38.45 | 41.11 | 35.50 |
| 1999/00 | 164,059 | 81,820 | 82,239 | 74,317 | 41,033 | 33,284 | 45.30 | 50.15 | 40.47 |
| 2000/01 | 169,628 | 84,683 | 84,945 | 76,564 | 41,457 | 35,107 | 45.14 | 48.96 | 41.33 |
| 2001/02 | 175,758 | 87,947 | 87,811 | 80,882 | 46,215 | 34,667 | 46.02 | 52.55 | 39.48 |
| 2002/03 | 178,245 | 88,891 | 89,354 | 87,019 | 50,138 | 36,881 | 48.82 | 56.40 | 41.28 |
| | Population 12-14 | | | | | | | | |
| 2003/04 | 274,014 | 136,804 | 137,210 | 122,966 | 73,742 | 49,224 | 44.87 | 53.90 | 35.87 |
| 2004/05 | 287,129 | 143,975 | 143,154 | 139,029 | 85,033 | 53,996 | 48.42 | 59.06 | 37.72 |

Chart 9. Middle level: Enrolment by academic year and gender

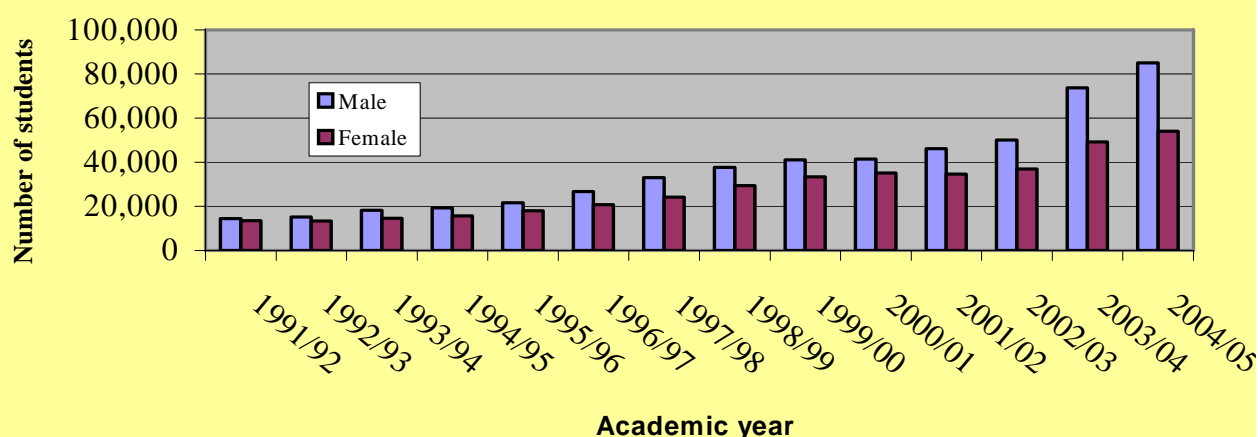

Table 22. Middle level: Gross Enrolment Ratio by region, 2004/05

| Region | Population age 12-14 | Gross enrolment | Gross enrolment ratio | Deviation from national ratio |
|----------------|----------------------|-----------------|-----------------------|-------------------------------|
| Anseba | 40,808 | 17,463 | 42.8 | -5.6 |
| Deb-Keih-Bahri | 6,140 | 1,742 | 28.4 | -20.0 |
| Debab | 72,458 | 45,406 | 62.7 | 14.3 |
| Gash Barka | 67,409 | 18,137 | 26.9 | -21.5 |
| Makel | 51,975 | 46,036 | 88.6 | 40.2 |
| Sem-Keih-Bahri | 48,339 | 10,245 | 21.2 | -27.2 |
| Total | 287,129 | 139,029 | 48.4 | 0.0 |

4. Net enrolment ratio

Table 23. Middle level: Net Enrolment Ratio 1991/92-2004/05

| Year | Population 12-14 | | | Net enrolment | | | Net enrolment ratio | | |
|---------|-------------------------|---------|---------|---------------|--------|--------|---------------------|-------|--------|
| | Total | Male | Female | Total | Male | Female | Total | Male | Female |
| 1991/92 | 136,712 | 72,904 | 63,808 | 9,727 | 5,111 | 4,616 | 7.11 | 7.01 | 7.23 |
| 1992/93 | 141,576 | 75,657 | 65,919 | 7,941 | 4,275 | 3,666 | 5.61 | 5.65 | 5.56 |
| 1993/94 | 146,349 | 78,209 | 68,140 | 8,594 | 4,604 | 3,990 | 5.87 | 5.89 | 5.86 |
| 1994/95 | 151,058 | 80,597 | 70,461 | 9,074 | 4,763 | 4,311 | 6.01 | 5.91 | 6.12 |
| 1995/96 | 155,725 | 82,856 | 72,869 | 9,988 | 5,299 | 4,689 | 6.41 | 6.40 | 6.43 |
| 1996/97 | 160,363 | 85,015 | 75,348 | 12,604 | 6,925 | 5,679 | 7.86 | 8.15 | 7.54 |
| 1997/98 | 164,331 | 86,762 | 77,569 | 14,751 | 8,062 | 6,689 | 8.98 | 9.29 | 8.62 |
| 1998/99 | 174,295 | 91,783 | 82,512 | 15,878 | 8,400 | 7,478 | 9.11 | 9.15 | 9.06 |
| 1999/00 | 164,059 | 81,820 | 82,239 | 18,201 | 9,552 | 8,649 | 11.09 | 11.67 | 10.52 |
| 2000/01 | 169,628 | 84,683 | 84,945 | 20,409 | 10,639 | 9,770 | 12.03 | 12.56 | 11.50 |
| 2001/02 | 175,758 | 87,947 | 87,811 | 22,348 | 11,718 | 10,630 | 12.72 | 13.32 | 12.11 |
| 2002/03 | 178,245 | 88,891 | 89,354 | 24,584 | 13,057 | 11,527 | 13.80 | 14.70 | 12.90 |
| | Population 12-14 | | | | | | | | |
| 2003/04 | 274,014 | 136,804 | 137,210 | 51,795 | 28,632 | 23,163 | 18.90 | 20.93 | 16.88 |
| 2004/05 | 287,129 | 143,975 | 143,154 | 60,323 | 33,879 | 26,444 | 21.01 | 23.53 | 18.47 |

Table 24. Middle level: Net enrolment ratio by region 2004/05

| Region | Population age 12-13 | Net enrolment | Net enrolment ratio | Deviation from national ratio |
|----------------|----------------------|---------------|---------------------|-------------------------------|
| Anseba | 40,808 | 7,369 | 18.1 | -2.9 |
| Deb-Keih-Bahri | 6,140 | 679 | 11.1 | -9.9 |
| Debub | 72,458 | 18,833 | 26.0 | 5.0 |
| Gash-Barka | 67,409 | 7,225 | 10.7 | -10.3 |
| Maekel | 51,975 | 22,566 | 43.4 | 22.4 |
| Sem-Keih-Bahri | 48,339 | 3,651 | 7.6 | -13.4 |
| Total | 287,129 | 60,323 | 21.0 | 0.0 |

5. Percentage of repeaters

Table 25. Middle level: Total number and percentage of repeaters 1991/92-2004/05

| Year | Enrolment | | | Repeaters | | | Percentage of repeaters | | |
|---------|-----------|--------|--------|-----------|--------|--------|-------------------------|------|--------|
| | Total | Male | Female | Total | Male | Female | Total | Male | Female |
| 1991/92 | 27,917 | 14,414 | 13,503 | N.A. | N.A. | N.A. | N.A. | N.A. | N.A. |
| 1992/93 | 28,431 | 15,052 | 13,379 | 12,256 | 4,116 | 8,140 | 43.1 | 27.3 | 60.8 |
| 1993/94 | 32,781 | 18,129 | 14,652 | 5,544 | 2,120 | 3,424 | 16.9 | 11.7 | 23.4 |
| 1994/95 | 34,995 | 19,310 | 15,685 | 4,736 | 1,781 | 2,955 | 13.5 | 9.2 | 18.8 |
| 1995/96 | 39,751 | 21,648 | 18,103 | 5,329 | 1,918 | 3,411 | 13.4 | 8.9 | 18.8 |
| 1996/97 | 47,460 | 26,739 | 20,721 | 6,193 | 2,385 | 3,808 | 13.1 | 8.9 | 18.4 |
| 1997/98 | 57,152 | 32,998 | 24,154 | 8,707 | 3,401 | 5,306 | 15.2 | 10.3 | 22.0 |
| 1998/99 | 67,021 | 37,731 | 29,290 | 12,119 | 5,042 | 7,077 | 18.1 | 13.4 | 24.2 |
| 1999/00 | 74,317 | 41,033 | 33,284 | 15,632 | 7,053 | 8,579 | 21.0 | 17.2 | 25.8 |
| 2000/01 | 76,564 | 41,457 | 35,107 | 16,870 | 8,025 | 8,845 | 22.0 | 19.4 | 25.2 |
| 2001/02 | 80,882 | 46,215 | 34,667 | 17,419 | 9,029 | 8,390 | 21.5 | 19.5 | 24.2 |
| 2002/03 | 87,019 | 50,138 | 36,881 | 23,126 | 12,163 | 10,963 | 26.6 | 24.3 | 29.7 |
| 2003/04 | 122,966 | 73,742 | 49,224 | 21,352 | 12,648 | 8,704 | 17.4 | 17.2 | 17.7 |
| 2004/05 | 139,029 | 85,033 | 53,996 | 15,737 | 10,451 | 5,286 | 11.3 | 12.3 | 9.8 |

The total percentage of repeaters had been declining between 1992/93 and 1996/97 but has been increasing in the last five years except in the academic year 2001/02. In 2002/03 the percentage of repeaters was 26.6 and it has decreased in the following academic years to 17.4 and 11.3 percent respectively.

VII. Secondary level

1. Duration

The duration of Secondary level is four years (Grade 9-12).

2. Enrolment

Enrolment for the academic year 2004/2005 was 76,051. Female enrolment constitutes 26,041 (34.2%). Approximately 3.6% of the students in the Secondary level were attending non-government schools.

**Table 26. Secondary level: Enrolment by gender and Region 2004/05
(Government and non-government)**

| Region | Total 9-12 | | |
|----------------|---------------|--------------|--------------|
| | Total | Male | Female |
| Anseba | 7,042 | 4651 | 2391 |
| Deb-Keih-Bahri | 919 | 658 | 261 |
| Debub | 21,788 | 15552 | 6236 |
| Gash-Barka | 5,812 | 4319 | 1493 |
| Maekel | 29,171 | 15948 | 13223 |
| Sem-Keih-Bahri | 3,455 | 2597 | 858 |
| Sawa | 7,864 | 6285 | 1579 |
| Total | 76,051 | 50010 | 26041 |

Chart 10. Secondary level: Enrolment by region and gender 2004/05

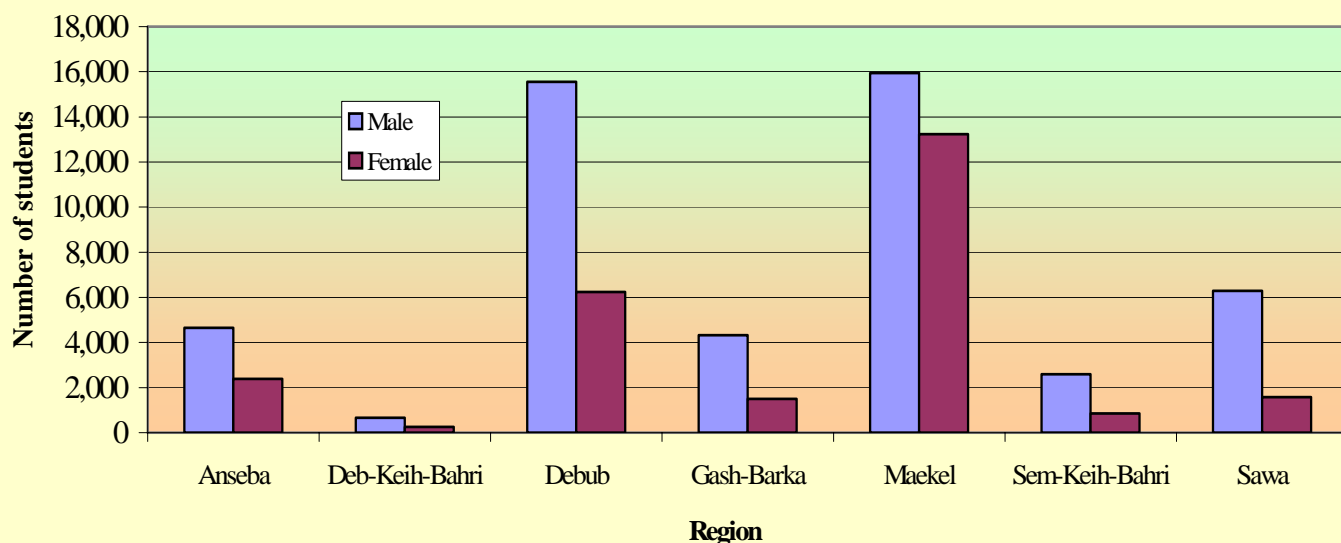

3. Gross enrolment ratio

Table 27. Secondary level: Gross enrolment ratio 1991/92-2004/05

| Year | Population 14-17 | | | Enrolment | | | Gross enrolment ratio | | |
|---------|------------------|---------|---------|-----------|--------|--------|-----------------------|-------|--------|
| | Total | Male | Female | Total | Male | Female | Total | Male | Female |
| 1991/92 | 210,515 | 110,133 | 100,382 | 27,627 | 14,281 | 13,346 | 13.12 | 12.97 | 13.30 |
| 1992/93 | 217,998 | 114,293 | 103,705 | 31,531 | 17,141 | 14,390 | 14.46 | 15.00 | 13.88 |
| 1993/94 | 225,344 | 118,144 | 107,200 | 32,756 | 19,432 | 13,324 | 14.54 | 16.45 | 12.43 |
| 1994/95 | 232,603 | 121,753 | 110,850 | 36,728 | 22,097 | 14,631 | 15.79 | 18.15 | 13.20 |
| 1995/96 | 239,805 | 125,167 | 114,638 | 39,188 | 23,713 | 15,475 | 16.34 | 18.95 | 13.50 |
| 1996/97 | 246,964 | 128,427 | 118,537 | 40,594 | 24,262 | 16,332 | 16.44 | 18.89 | 13.78 |
| 1997/98 | 253,097 | 131,066 | 122,031 | 41,615 | 25,198 | 16,417 | 16.44 | 19.23 | 13.45 |
| 1998/99 | 268,460 | 138,652 | 129,808 | 47,533 | 29,777 | 17,756 | 17.71 | 21.48 | 13.68 |
| 1999/00 | 272,871 | 139,459 | 133,412 | 59,626 | 37,533 | 22,093 | 21.85 | 26.91 | 16.56 |
| 2000/01 | 282,140 | 144,338 | 137,802 | 63,951 | 40,355 | 23,596 | 22.67 | 27.96 | 17.12 |
| 2001/02 | 292,355 | 149,903 | 142,452 | 70,183 | 45,129 | 25,054 | 24.01 | 30.11 | 17.59 |
| 2002/03 | 296,466 | 151,511 | 144,955 | 72,818 | 46,633 | 26,185 | 24.60 | 30.80 | 18.10 |
| | Population 15-18 | | | Enrolment | | | Gross enrolment ratio | | |
| 2003/04 | 296,218 | 151,315 | 144,903 | 69,401 | 46,449 | 22,952 | 23.4 | 30.7 | 15.8 |
| 2004/05 | 316,462 | 160,167 | 156,295 | 76,051 | 50,010 | 26,041 | 24.0 | 31.2 | 16.7 |

Table 28. Secondary level: Gross enrolment ratio by region 2004/05

| Region | Population age 15-18 | Gross enrolment | Gross enrolment ratio | Deviation from national ratio |
|----------------|----------------------|-----------------|-----------------------|-------------------------------|
| Anseba | 44,978 | 7,042 | 15.7 | -8.3 |
| Deb-Keih-Bahri | 6,767 | 919 | 13.6 | -10.4 |
| Debub | 79,861 | 21,788 | 27.3 | 3.3 |
| Gash Barka | 74,295 | 5,812 | 7.8 | -16.2 |
| Maekel | 57,283 | 29,171 | 50.9 | 26.9 |
| Sem-Keih-Bahri | 53,278 | 3,455 | 6.5 | -17.5 |
| Sawa | | 7,864 | | |
| Total | 316,462 | 76,051 | 24.0 | 0.0 |

Chart 11. Secondary level: Enrolment by academic year and gender

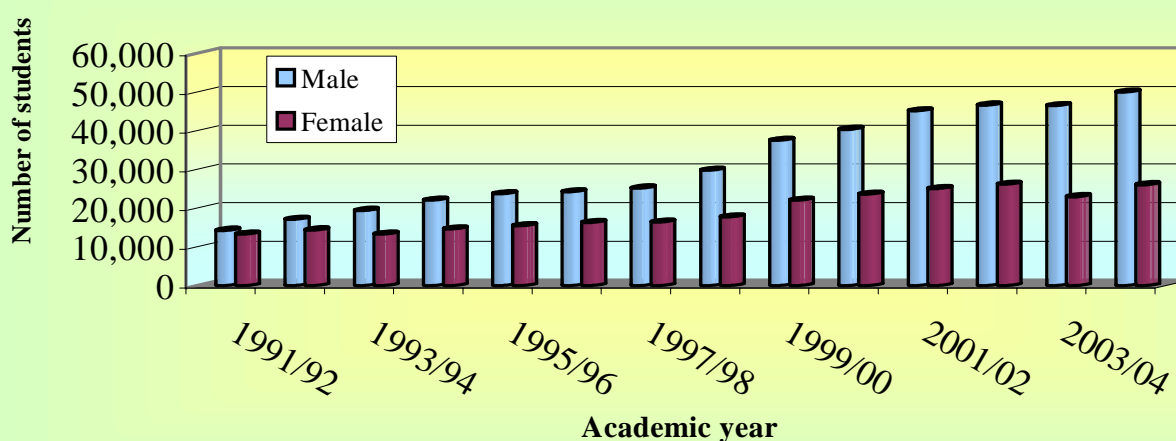

4. Net enrolment ratio

Table 29: Secondary level: Net enrolment ratio 1991/92-2004/05

| Year | Population 14-17 | | | Net enrolment | | | Net enrolment ratio (NER) | | |
|---------|------------------|---------|---------|---------------|--------|--------|---------------------------|-------|--------|
| | Total | Male | Female | Total | Male | Female | Total | Male | Female |
| 1991/92 | 210,515 | 110,133 | 100,382 | 19,131 | 9,999 | 9,132 | 9.09 | 9.08 | 9.10 |
| 1992/93 | 217,998 | 114,293 | 103,705 | 19,880 | 9,951 | 9,929 | 9.12 | 8.71 | 9.57 |
| 1993/94 | 225,344 | 118,144 | 107,200 | 19,097 | 9,932 | 9,165 | 8.47 | 8.41 | 8.55 |
| 1994/95 | 232,603 | 121,753 | 110,850 | 22,108 | 11,584 | 10,524 | 9.50 | 9.51 | 9.49 |
| 1995/96 | 239,805 | 125,167 | 114,638 | 23,780 | 12,788 | 10,992 | 9.92 | 10.22 | 9.59 |
| 1996/97 | 246,964 | 128,427 | 118,537 | 25,911 | 13,822 | 12,089 | 10.49 | 10.76 | 10.20 |
| 1997/98 | 253,097 | 131,066 | 122,031 | 27,357 | 14,817 | 12,540 | 10.81 | 11.30 | 10.28 |
| 1998/99 | 268,460 | 138,652 | 129,808 | 30,995 | 17,755 | 13,240 | 11.55 | 12.81 | 10.20 |
| 1999/00 | 272,871 | 139,459 | 133,412 | 39,197 | 22,800 | 16,397 | 14.36 | 16.35 | 12.29 |
| 2000/01 | 282,140 | 144,338 | 137,802 | 38,271 | 22,482 | 15,789 | 13.56 | 15.58 | 11.46 |
| 2001/02 | 292,355 | 149,903 | 142,452 | 41,748 | 24,906 | 16,842 | 14.28 | 16.61 | 11.82 |
| 2002/03 | 296,466 | 151,511 | 144,955 | 48,269 | 28,612 | 19,657 | 16.30 | 18.90 | 13.60 |
| | Population 15-18 | | | Net enrolment | | | NER | | |
| 2003/04 | 296,218 | 151,315 | 144,903 | 41,757 | 25,549 | 16,208 | 14.10 | 16.89 | 11.19 |
| 2004/05 | 316,462 | 160,167 | 156,295 | 41,523 | 24,702 | 16,821 | 13.12 | 15.42 | 10.76 |

Table 30. Secondary level: Net enrolment ratio by region 2004/05

| Region | Population age 15-18 | Net enrolment | Net enrolment ratio | Deviation from national ratio |
|----------------|----------------------|---------------|---------------------|-------------------------------|
| Anseba | 44,978 | 4,274 | 9.5 | -3.6 |
| Deb-Keih-Bahri | 6,767 | 703 | 10.4 | -2.7 |
| Debub | 79,861 | 11,843 | 14.8 | 1.7 |
| Gash-Barka | 74,295 | 3,457 | 4.7 | -8.4 |
| Maekel | 57,283 | 18,331 | 32.0 | 18.9 |
| Sem-Keih-Bahri | 53,278 | 2,306 | 4.3 | -8.8 |
| Sawa | | 606 | | -13.1 |
| Total | 316,462 | 41,520 | 13.1 | 0.0 |

Chart 12. Secondary level: GER and NER by gender and academic year

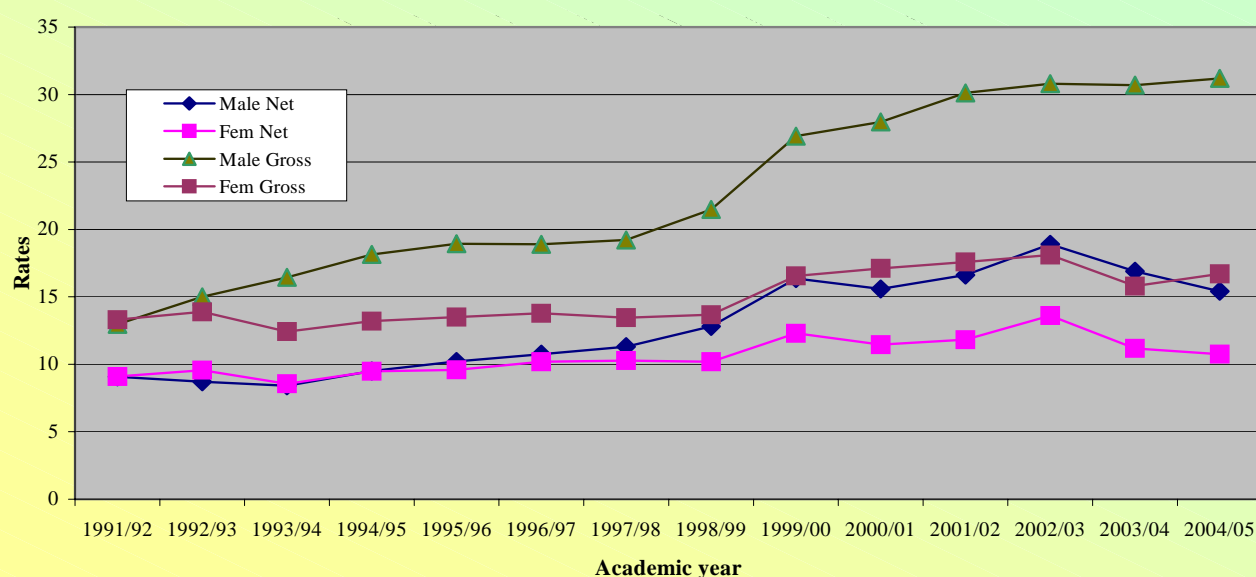

5. Percentage of repeaters

Table 31. Secondary level: Total number and percentage of repeaters by gender 1991/92-2004/05

| Year | Enrolment | | | Repeaters | | | Percentage | | |
|---------|-----------|--------|--------|-----------|-------|--------|------------|------|--------|
| | Total | Male | Female | Total | Male | Female | Total | Male | Female |
| 1991/92 | 27,627 | 14,281 | 13,346 | 11,072 | 4,241 | 6,831 | 40.1 | 29.7 | 51.2 |
| 1992/93 | 31,531 | 17,141 | 14,390 | 11,426 | 4,341 | 7,085 | 36.2 | 25.3 | 49.2 |
| 1993/94 | 32,756 | 19,432 | 13,324 | 7,504 | 3,212 | 4,292 | 22.9 | 16.5 | 32.2 |
| 1994/95 | 36,728 | 22,097 | 14,631 | 6,182 | 2,704 | 3,478 | 16.8 | 12.2 | 23.8 |
| 1995/96 | 39,188 | 23,713 | 15,475 | 7,296 | 3,113 | 4,183 | 18.6 | 13.1 | 27.0 |
| 1996/97 | 40,594 | 24,262 | 16,332 | 7,135 | 3,272 | 3,863 | 17.6 | 13.5 | 23.7 |
| 1997/98 | 41,615 | 25,198 | 16,417 | 7,648 | 3,305 | 4,343 | 18.4 | 13.1 | 26.4 |
| 1998/99 | 47,533 | 29,777 | 17,756 | 5,941 | 2,813 | 3,128 | 12.4 | 9.4 | 17.6 |
| 1999/00 | 57,334 | 36,504 | 20,830 | 7,640 | 3,999 | 3,641 | 13.3 | 11.0 | 17.5 |
| 2000/01 | 63,951 | 40,355 | 23,596 | 11,627 | 6,747 | 4,880 | 18.2 | 16.7 | 20.7 |
| 2001/02 | 70,183 | 45,129 | 25,054 | 13,321 | 7,902 | 5,419 | 19.0 | 17.5 | 21.6 |
| 2002/03 | 72,818 | 46,633 | 26,185 | 13,922 | 8,363 | 5,559 | 19.1 | 17.9 | 21.2 |
| | Enrolment | | | Repeaters | | | Percentage | | |
| 2003/04 | 69,401 | 46,449 | 22,952 | 11,437 | 7,418 | 4,019 | 16.8 | 16.0 | 17.5 |
| 2004/05 | 76,051 | 50,010 | 26,041 | 4,066 | 3,258 | 808 | 5.3 | 6.5 | 3.1 |

VIII. Internal efficiency

1. Length of school year.

The duration of the school year in the academic year 2004/05 was 197 days in the highlands and 192 days in the lowlands. In both locations the number of periods per week in grades 1-2 and 3-5 was 25 and 35 respectively. (There are 5 periods for grades 1-2 in a day and 7 periods for grades 3-5 in a day). In other grades the number of periods per week is 35.

In the academic year 2004/2005, schooling in the highlands began in September 20 and ended in June 30. In the lowlands it began in September 20 and ended in May 30. Schools in the lowlands teach 6 days a week while schools in the highlands teach 5 days a week.

The duration of the school year in the academic 2004/2005 is shown in table 31.

Table 32. Elementary level: Duration of school year

| Grade | Location | Periods per day | School days per Year | Total number of periods | Total number of contact hrs. |
|-------|----------|-----------------|----------------------|-------------------------|------------------------------|
| 1 | Highland | 5 | 197 | 985 | 657 |
| | Lowland | 5 | 192 | 960 | 640 |
| 2 | Highland | 5 | 197 | 985 | 657 |
| | Lowland | 5 | 192 | 960 | 640 |
| 3 | Highland | 7 | 197 | 1379 | 919 |
| | Lowland | 7 | 192 | 1344 | 896 |
| 4 | Highland | 7 | 197 | 1379 | 919 |
| | Lowland | 7 | 192 | 1344 | 896 |
| 5 | Highland | 7 | 197 | 1379 | 919 |
| | Lowland | 7 | 192 | 1344 | 896 |

2. Elementary level: Percentage of repeaters

Table 33. Elementary level: Enrolment, repeaters and percent of repeaters by gender 1991/92-2004/05

| Year | Enrolment | | | Repeaters | | | Percentage of repeaters | | |
|---------|-----------|---------|---------|-----------|--------|--------|-------------------------|-------|--------|
| | Total | Male | Female | Total | Male | Female | Total | Male | Female |
| 1991/92 | 150,982 | 81,746 | 69,236 | N. A. | N.A. | N. A. | N.A. | N. A. | N.A. |
| 1992/93 | 184,656 | 102,235 | 82,421 | 47,139 | 23,289 | 23,850 | 25.5 | 22.8 | 28.9 |
| 1993/94 | 208,199 | 115,663 | 92,536 | 41,694 | 20,632 | 21,062 | 20.0 | 17.8 | 22.8 |
| 1994/95 | 224,287 | 124,544 | 99,743 | 42,426 | 21,177 | 21,249 | 18.9 | 17.0 | 21.3 |
| 1995/96 | 241,725 | 133,471 | 108,254 | 49,172 | 24,470 | 24,702 | 20.3 | 18.3 | 22.8 |
| 1996/97 | 240,737 | 132,250 | 108,487 | 49,246 | 25,006 | 24,240 | 20.5 | 18.9 | 22.3 |
| 1997/98 | 247,499 | 135,569 | 111,930 | 56,157 | 28,613 | 27,544 | 22.7 | 21.1 | 24.6 |
| 1998/99 | 261,963 | 143,578 | 118,385 | 50,820 | 26,168 | 24,652 | 19.4 | 18.2 | 20.8 |
| 1999/00 | 295,941 | 162,896 | 133,045 | 57,366 | 30,798 | 26,568 | 19.4 | 18.9 | 20.0 |
| 2000/01 | 298,691 | 164,523 | 134,168 | 41,387 | 22,499 | 18,888 | 13.9 | 13.7 | 14.1 |
| 2001/02 | 330,278 | 184,060 | 146,218 | 47,249 | 21,005 | 26,244 | 14.3 | 11.4 | 17.9 |
| 2002/03 | 359,399 | 199,842 | 159,557 | 73,114 | 39,485 | 33,629 | 20.3 | 19.8 | 21.1 |
| 2003/04 | 374,997 | 209,043 | 165,954 | 80,020 | 43,208 | 36,812 | 21.3 | 20.7 | 22.2 |
| 2004/05 | 377,512 | 210,061 | 167,451 | 48,629 | 27,373 | 21,256 | 12.9 | 13.0 | 12.7 |

3. All grades: Flow rates

Table 34. All grades: Flow rates by gender and grade 2004/05

| Grade | Dropout | | | Repetition | | | Promotion | | |
|-------|-------------|-------------|-------------|-------------|-------------|-------------|-------------|-------------|-------------|
| | Male % | Fem. % | Tot % | Male % | Fem. % | Tot % | Male % | Fem. % | Tot % |
| 1 | 7.1 | 5.4 | 6.3 | 15.4 | 15.4 | 15.4 | 77.6 | 79.1 | 78.3 |
| 2 | 4.6 | 3.3 | 4.0 | 17.1 | 17.1 | 17.1 | 78.4 | 79.6 | 78.9 |
| 3 | 4.7 | 3.5 | 4.2 | 15.8 | 15.8 | 15.8 | 79.6 | 80.7 | 80.1 |
| 4 | 5.5 | 4.3 | 5.0 | 17.0 | 17.4 | 17.2 | 77.5 | 78.3 | 77.8 |
| 5 | 5.6 | 5.0 | 5.3 | 10.1 | 9.9 | 10.0 | 84.3 | 85.1 | 84.6 |
| 1-5 | 5.5 | 4.3 | 5.0 | 15.3 | 15.4 | 15.3 | 79.2 | 80.3 | 79.7 |
| 6 | 8.3 | 6.6 | 7.7 | 17.9 | 14.8 | 16.7 | 73.7 | 78.5 | 75.6 |
| 7 | 8.7 | 7.0 | 8.0 | 21.3 | 15.0 | 18.8 | 70.0 | 78.0 | 73.2 |
| 8 | 10.2 | 7.4 | 9.1 | 19.9 | 11.2 | 16.5 | 69.9 | 81.4 | 74.4 |
| 6-8 | 9.0 | 7.0 | 8.2 | 19.6 | 13.8 | 17.3 | 71.4 | 79.2 | 74.5 |
| 9 | 10.4 | 6.2 | 8.8 | 4.5 | 1.2 | 3.3 | 85.1 | 92.6 | 87.9 |
| 10 | 17.8 | 8.8 | 14.6 | 13.4 | 3.2 | 9.8 | 68.7 | 88.0 | 75.6 |
| 11 | 29.1 | 20.5 | 26.1 | 7.0 | 4.4 | 6.1 | 63.9 | 75.2 | 67.8 |
| 12 | | | | | | | | | |
| 9-12 | 17.8 | 10.2 | 15.0 | 9.1 | 2.7 | 6.8 | 73.1 | 87.1 | 78.2 |

4. Elementary level: Flow rates

Table 35. Elementary level: Flow rates 2004/05

| Grade | Dropout | | | Repetition | | | Promotion | | |
|-------|------------|------------|------------|-------------|-------------|-------------|-------------|-------------|-------------|
| | Male % | Fem. % | Tot % | Male % | Fem. % | Tot % | Male % | Fem. % | Tot % |
| 1 | 7.1 | 5.4 | 6.3 | 15.4 | 15.4 | 15.4 | 77.6 | 79.1 | 78.3 |
| 2 | 4.6 | 3.3 | 4.0 | 17.1 | 17.1 | 17.1 | 78.4 | 79.6 | 78.9 |
| 3 | 4.7 | 3.5 | 4.2 | 15.8 | 15.8 | 15.8 | 79.6 | 80.7 | 80.1 |
| 4 | 5.5 | 4.3 | 5.0 | 17.0 | 17.4 | 17.2 | 77.5 | 78.3 | 77.8 |
| 5 | 5.6 | 5.0 | 5.3 | 10.1 | 9.9 | 10.0 | 84.3 | 85.1 | 84.6 |
| Total | 5.5 | 4.3 | 5.0 | 15.3 | 15.4 | 15.3 | 79.2 | 80.3 | 79.7 |

5. Middle level: Flow rates

Table 36. Middle level: Flow rates 2004/05

| Grade | Dropout | | | Repetition | | | Promotion | | |
|--------------|------------|------------|------------|-------------|-------------|-------------|-------------|-------------|-------------|
| | Male % | Fem. % | Tot % | Male % | Fem. % | Tot % | Male % | Fem. % | Tot % |
| 6 | 8.3 | 6.6 | 7.7 | 17.9 | 14.8 | 16.7 | 73.7 | 78.5 | 75.6 |
| 7 | 8.7 | 7.0 | 8.0 | 21.3 | 15.0 | 18.8 | 70.0 | 78.0 | 73.2 |
| 8 | 10.2 | 7.4 | 9.1 | 19.9 | 11.2 | 16.5 | 69.9 | 81.4 | 74.4 |
| Total | 9.0 | 7.0 | 8.2 | 19.6 | 13.8 | 17.3 | 71.4 | 79.2 | 74.5 |

6. Secondary level: Flow rates

Table 37. Secondary level: Flow rates 2004/05

| Grade | Dropout | | | Repetition | | | Promotion | | |
|--------------|-------------|-------------|-------------|------------|------------|------------|-------------|-------------|-------------|
| | Male % | Fem. % | Tot % | Male % | Fem. % | Tot % | Male % | Fem. % | Tot % |
| 9 | 10.4 | 6.2 | 8.8 | 4.5 | 1.2 | 3.3 | 85.1 | 92.6 | 87.9 |
| 10 | 17.8 | 8.8 | 14.6 | 13.4 | 3.2 | 9.8 | 68.7 | 88.0 | 75.6 |
| 11 | 29.1 | 20.5 | 26.1 | 7.0 | 4.4 | 6.1 | 63.9 | 75.2 | 67.8 |
| 12 | | | | | | | | | |
| Total | 17.8 | 10.2 | 15.0 | 9.1 | 2.7 | 6.8 | 73.1 | 87.1 | 78.2 |

7. Elementary level: Zoba flow ratios

Table 38. Elementary level: Average flow rates 2004/05

| Eritrea | Grade | 1 | 2 | 3 | 4 | 5 |
|-------------------------|-------------------------|------------------------|------|------|------|------|
| | Eritrea | Promotion ratio | 78.3 | 78.9 | 80.1 | 77.8 |
| Repetition ratio | | 15.4 | 17.1 | 15.8 | 17.2 | 10.0 |
| Dropout ratio | | 6.3 | 4.0 | 4.2 | 5.0 | 5.3 |
| Anseba | Promotion ratio | 82.5 | 80.2 | 82.0 | 75.8 | 84.3 |
| | Repetition ratio | 12.1 | 16.1 | 13.6 | 19.1 | 10.1 |
| | Dropout ratio | 5.4 | 3.7 | 4.4 | 5.1 | 5.6 |
| Deb-Keih-B | Promotion ratio | 67.4 | 75.9 | 80.7 | 83.3 | 87.3 |
| | Repetition ratio | 22.8 | 19.9 | 15.2 | 13.0 | 9.9 |
| | Dropout ratio | 9.8 | 4.3 | 3.4 | 3.5 | 2.9 |
| Debub | Promotion ratio | 77.1 | 79.7 | 79.9 | 79.0 | 84.6 |
| | Repetition ratio | 17.1 | 16.7 | 16.3 | 16.1 | 9.9 |
| | Dropout ratio | 5.9 | 3.6 | 3.8 | 5.0 | 5.5 |
| Gash-Barka | Promotion ratio | 73.5 | 72.7 | 74.9 | 71.6 | 80.0 |
| | Repetition ratio | 17.2 | 20.5 | 18.5 | 20.4 | 11.7 |
| | Dropout ratio | 9.2 | 6.9 | 6.6 | 8.0 | 8.3 |
| Maekel | Promotion ratio | 85.9 | 85.1 | 85.5 | 83.4 | 88.9 |
| | Repetition ratio | 10.3 | 13.2 | 12.6 | 14.4 | 8.3 |
| | Dropout ratio | 3.8 | 1.7 | 1.9 | 2.2 | 2.8 |
| Sem-Keih-B | Promotion ratio | 74.6 | 77.5 | 79.3 | 75.3 | 80.8 |
| | Repetition ratio | 18.3 | 18.8 | 17.1 | 19.4 | 13.0 |
| | Dropout ratio | 7.1 | 3.7 | 3.6 | 5.3 | 6.2 |

8. Elementary level: Cohort Reconstruction

Figure 1-7 are constructed based on the actual flow ratios of the 2004/2005 academic year indicated in table 38.

Figure 1: Elementary level: hypothetical cohort reconstruction (Constant)

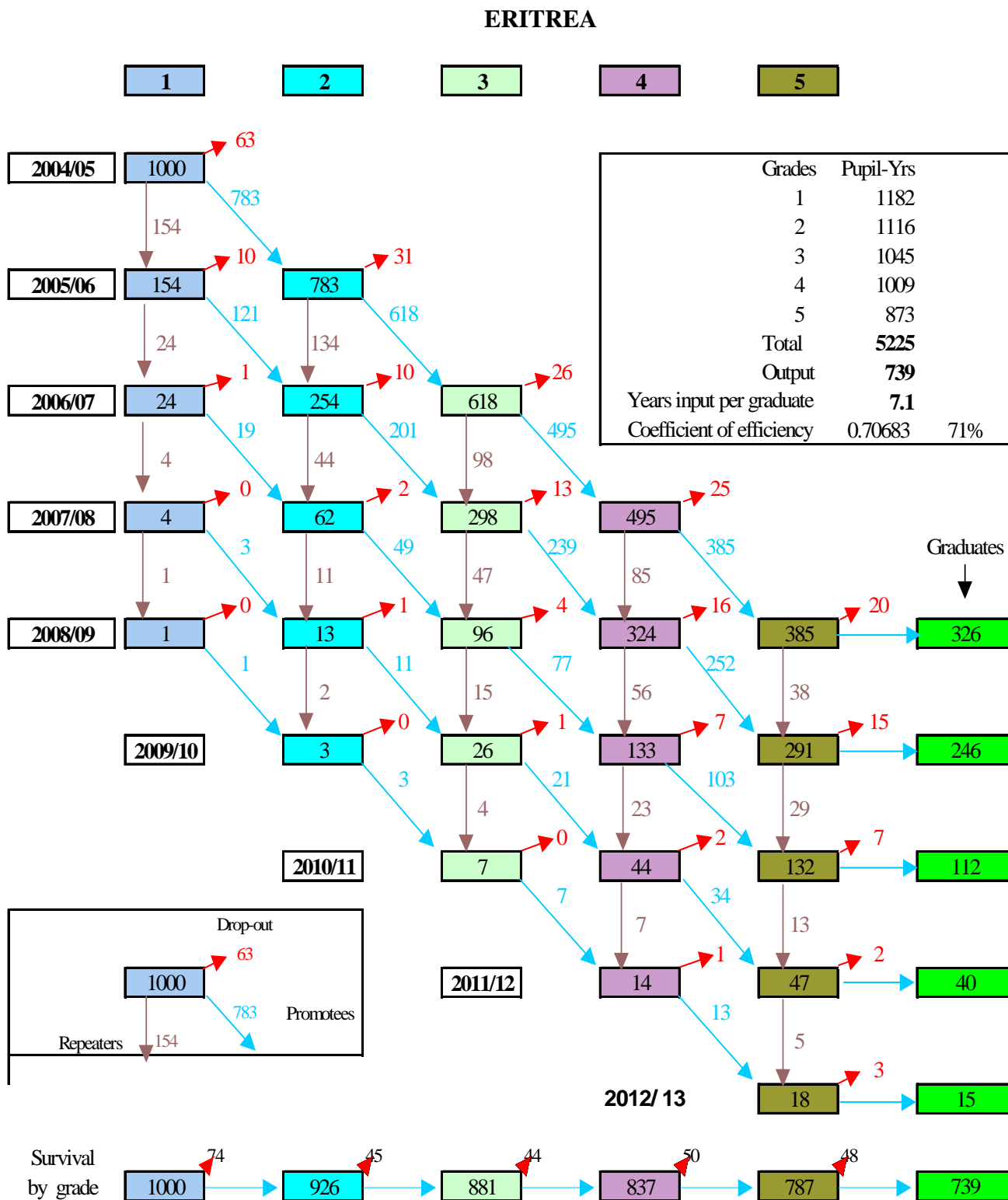
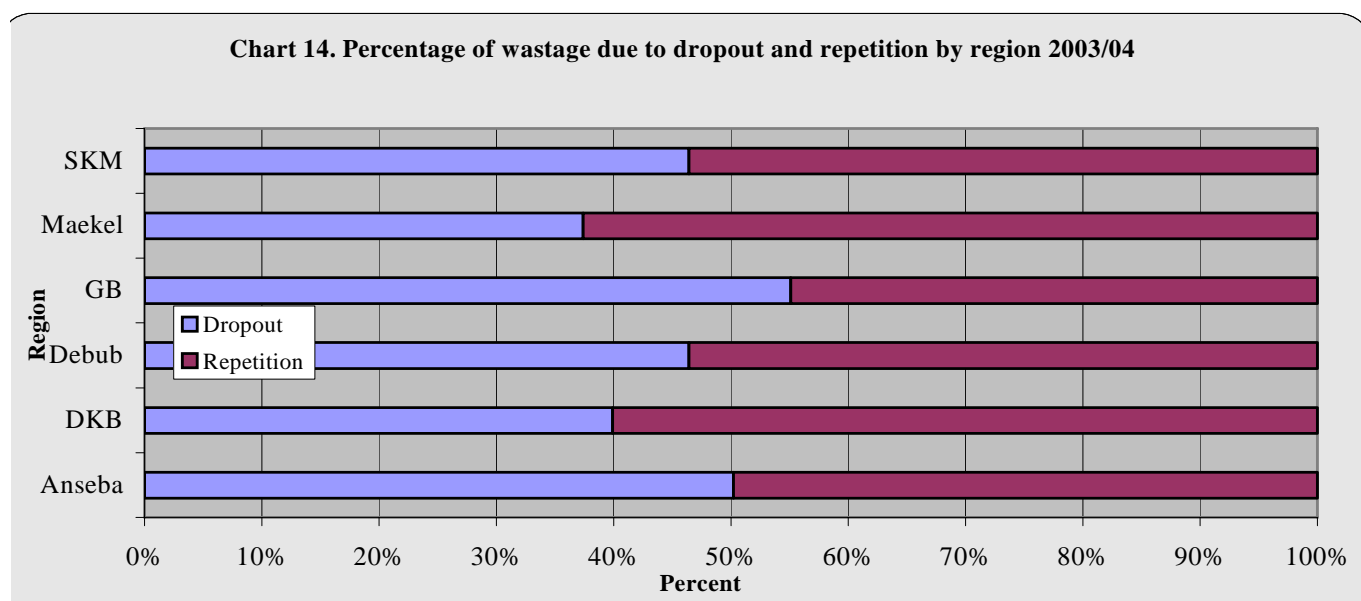
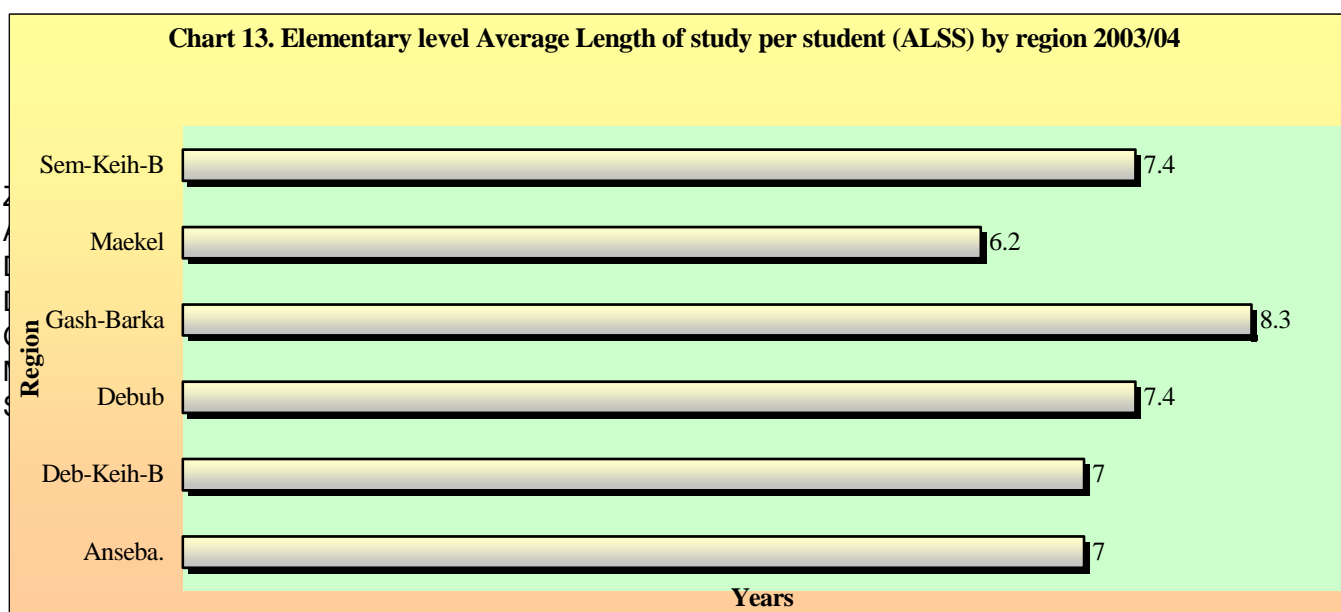

Table 39. Eritrea elementary level: Wastage, survival and transition ratios by region

(Based on the 2004/2005 flow ratios and cohort reconstruction of each region)

| | Internal efficiency ratios | Total | ANS | DKB | DEB | GASH | MAKL | SKB |
|---|--|-------|------|------|------|------|------|------|
| 1 | Elementary level: Wastage ratio | 1.41 | 1.40 | 1.40 | 1.48 | 1.65 | 1.23 | 1.48 |
| 2 | Survival ratio for Grade 2 | 92.6 | 93.9 | 87.3 | 91.3 | 88.9 | 95.8 | 91.3 |
| | Survival ratio for Grade 3 | 88.1 | 89.7 | 82.6 | 87.2 | 81.2 | 93.9 | 87.2 |
| | Survival ratio for Grade 4 | 83.7 | 85.2 | 79.3 | 83.4 | 74.6 | 91.8 | 83.4 |
| | Survival ratio for Grade 5 | 78.7 | 79.8 | 76.2 | 77.9 | 67.2 | 89.5 | 77.9 |
| 3 | Transition ratio from elementary level to middle level (No national exam.) | 73.9 | 74.7 | 72.9 | 72.0 | 60.6 | 86.7 | 72.0 |
| 4 | Proportion of total waste spent on dropouts | 48.2 | 50.2 | 39.9 | 46.4 | 55.1 | 37.4 | 46.4 |
| 5 | Proportion of total waste spent on repetition | 51.8 | 49.8 | 60.1 | 53.6 | 44.9 | 62.6 | 53.6 |
| 6 | Average length of study per graduate | 7.1 | 7.0 | 7.0 | 7.4 | 8.3 | 6.2 | 7.4 |



IX. Elementary, middle and Secondary level: Teaching staff

Table 40. Teachers: Gender and level by Region. 2004/05

| Region | 1-5 | | | 6-7 | | | 8-11 | | | Total | | |
|----------------|-------------|-------------|-------------|-------------|-------------|------------|-------------|-------------|------------|--------------|-------------|-------------|
| | Total | Male | Female | Total | Male | Female | Total | Male | Female | Total | Male | Female |
| Anseba | 1213 | 846 | 367 | 329 | 320 | 9 | 141 | 110 | 31 | 1683 | 1276 | 407 |
| Deb-Keih-Bahri | 162 | 133 | 29 | 31 | 30 | 1 | 26 | 25 | 1 | 219 | 188 | 31 |
| Dehub | 2570 | 1342 | 1228 | 713 | 656 | 57 | 378 | 335 | 43 | 3661 | 2333 | 1328 |
| Gash-Barka | 1623 | 1203 | 420 | 342 | 322 | 20 | 146 | 132 | 14 | 2111 | 1657 | 454 |
| Maekel | 1650 | 652 | 998 | 834 | 683 | 151 | 653 | 543 | 110 | 3137 | 1878 | 1259 |
| Sem-Keih-Bahri | 724 | 600 | 124 | 200 | 193 | 7 | 104 | 89 | 15 | 1028 | 882 | 146 |
| Sawa | | | | | | | 159 | 158 | 1 | 159 | 158 | 1 |
| Total | 7942 | 4776 | 3166 | 2449 | 2204 | 245 | 1607 | 1392 | 215 | 11998 | 8372 | 3626 |

1. Elementary, middle and Secondary level: Pupil/teacher ratio.

This ratio represents the average number of pupils per teacher at each level.

Table 41. Pupil /teacher ratio by year and level

| Year | Level | | | | | | | | |
|---------|---------|---------|---------------------|---------|---------|---------------------|--------|---------|---------------------|
| | 1-5 | | | 6-7 | | | 8-11 | | |
| | Pupil | Teacher | Pupil/teacher Ratio | Pupil | Teacher | Pupil/teacher Ratio | Pupil | Teacher | Pupil/teacher Ratio |
| 1991/92 | 150,982 | 3,647 | 41 | 27,917 | 783 | 36 | 27,627 | 758 | 36 |
| 1992/93 | 184,656 | 4,978 | 37 | 28,431 | 855 | 33 | 31,531 | 905 | 35 |
| 1993/94 | 208,199 | 5,272 | 39 | 32,781 | 978 | 34 | 32,756 | 1,015 | 32 |
| 1994/95 | 224,287 | 5,583 | 40 | 34,995 | 948 | 37 | 36,728 | 1,081 | 34 |
| 1995/96 | 241,725 | 5,828 | 41 | 39,751 | 992 | 40 | 39,188 | 1,039 | 38 |
| 1996/97 | 240,737 | 5,476 | 44 | 47,460 | 1,017 | 47 | 40,594 | 942 | 43 |
| 1997/98 | 247,499 | 5,799 | 43 | 57,152 | 1,162 | 49 | 41,615 | 959 | 43 |
| 1998/99 | 26,1963 | 5,576 | 47 | 67,021 | 1,208 | 56 | 47,533 | 982 | 49 |
| 1999/00 | 29,5941 | 6,229 | 48 | 74,317 | 1,312 | 57 | 57,334 | 1,047 | 55 |
| 2000/01 | 298,691 | 6,668 | 45 | 76,564 | 1,377 | 56 | 63,951 | 1,188 | 54 |
| 2001/02 | 330,278 | 7,498 | 44 | 80,882 | 1,529 | 53 | 70,183 | 1,419 | 50 |
| 2002/03 | 359,423 | 7,692 | 47 | 87,019 | 1,614 | 54 | 72,818 | 1,277 | 57 |
| | 1-5 | | | 6-8 | | | 9-12 | | |
| 2003/04 | 374,997 | 8,033 | 47 | 122,966 | 2,241 | 55 | 69,401 | 1,645 | 43 |
| 2004/05 | 377,512 | 7,942 | 48 | 139,029 | 2,449 | 57 | 76,051 | 1,607 | 47 |

2. Teachers' qualifications

Teachers in the elementary level are considered professionally qualified if they are graduates of the TTI or have an equivalent / higher qualification.

Teachers in the middle level are considered professionally qualified if they have a qualification of higher education diploma (12+2) or have an equivalent or higher qualification.

Teachers in the secondary level are considered technically qualified if they have a minimum qualification of Bachelor degree.

Table 42. Teachers' qualifications

| Year | Level | | | | | | | | |
|---------|-------|------------|----------------|-------|------------|----------------|-------|-------------|----------------|
| | 1-5 | | | 6-7 | | | 8-11 | | |
| | Total | Qualified | % of qualified | Total | Qualified | % of qualified | Total | Qualified | % of qualified |
| 1991/92 | N.A | N.A | N.A | N.A | N.A | N.A | N.A | N.A | N.A |
| 1992/93 | 4,978 | 2,128 | 42.7 | 855 | 484 | 56.6 | 905 | 431 | 47.6 |
| 1993/94 | 5,272 | 2,062 | 39.1 | 978 | 710 | 72.6 | 1,015 | 479 | 47.2 |
| 1994/95 | 5,583 | 2,675 | 47.9 | 948 | 661 | 69.7 | 1,081 | 507 | 46.9 |
| 1995/96 | 5,828 | 4,218 | 72.4 | 992 | 490 | 49.4 | 1,039 | 540 | 52.0 |
| 1996/97 | 5,476 | 3,747 | 68.4 | 1,017 | 446 | 43.9 | 942 | 527 | 55.9 |
| 1997/98 | 5,799 | 3,915 | 67.5 | 1,162 | 500 | 43.0 | 959 | 682 | 71.1 |
| 1998/99 | 5,576 | 4,058 | 72.8 | 1,208 | 459 | 37.9 | 982 | 715 | 72.8 |
| 1999/00 | 6,229 | 4,472 | 71.8 | 1,312 | 420 | 32.0 | 1,047 | 729 | 69.6 |
| 2000/01 | 6,668 | 4,699 | 70.5 | 1,377 | 486 | 35.3 | 1,188 | 869 | 73.1 |
| 2001/02 | 7,498 | 5,456 | 72.8 | 1,529 | 471 | 30.8 | 1,419 | 1,032 | 72.7 |
| 2002/03 | 7,692 | 6,194 | 80.5 | 1,614 | 507 | 31.4 | 1,277 | 870 | 68.1 |
| | | 1-5 | | | 6-8 | | | 9-12 | |
| 2003/04 | 8,033 | 6,675 | 83.1 | 2,241 | 633 | 28.2 | 1,645 | 1,294 | 78.6 |
| 2004/05 | 7,942 | 6,640 | 83.6 | 2,449 | 708 | 28.9 | 1,607 | 1,311 | 81.6 |

3. Female teachers

Table 43. Number and percentage of female teachers by level 1991/92-2004/05

| Academic Year | Level | | | | | | | | |
|---------------|-------|------------|-------------------|-------|------------|-------------------|-------|-------------|-------------------|
| | 1-5 | | | 6-7 | | | 8-11 | | |
| | Total | Female | Percent of female | Total | Female | Percent of female | Total | Female | Percent of female |
| 1991/92 | 3,647 | 1,411 | 38.7 | 783 | 139 | 17.8 | 758 | 67 | 8.8 |
| 1992/93 | 4,978 | 1,849 | 37.1 | 855 | 143 | 16.7 | 905 | 93 | 10.3 |
| 1993/94 | 5,272 | 1,865 | 35.4 | 978 | 140 | 14.3 | 1,015 | 104 | 10.2 |
| 1994/95 | 5,583 | 1,974 | 35.4 | 948 | 139 | 14.7 | 1,081 | 108 | 10.0 |
| 1995/96 | 5,828 | 2,025 | 34.7 | 992 | 156 | 15.7 | 1,039 | 103 | 9.9 |
| 1996/97 | 5,476 | 1,977 | 36.1 | 1,017 | 170 | 16.7 | 942 | 106 | 11.3 |
| 1997/98 | 5,799 | 1,893 | 32.6 | 1,162 | 170 | 14.6 | 959 | 113 | 11.8 |
| 1998/99 | 5,576 | 1,951 | 35.0 | 1,208 | 149 | 12.3 | 982 | 112 | 11.4 |
| 1999/00 | 6,229 | 2,330 | 37.4 | 1,312 | 167 | 12.7 | 1,047 | 109 | 10.4 |
| 2000/01 | 6,668 | 2,710 | 40.6 | 1,377 | 160 | 11.6 | 1,188 | 115 | 9.7 |
| 2001/02 | 7,498 | 2,873 | 38.3 | 1,529 | 177 | 11.6 | 1,419 | 145 | 10.2 |
| 2002/03 | 7,692 | 2,754 | 35.8 | 1,614 | 178 | 11.0 | 1,277 | 140 | 11.0 |
| | | 1-5 | | | 6-8 | | | 9-12 | |
| 2003/04 | 8,033 | 2,887 | 35.9 | 2,241 | 216 | 9.6 | 1,645 | 215 | 13.1 |
| 2004/05 | 7,942 | 3,166 | 39.9 | 2,449 | 245 | 10.0 | 1,607 | 215 | 13.4 |

Chart 15. Percent of female teachers 1991/92-2004/05

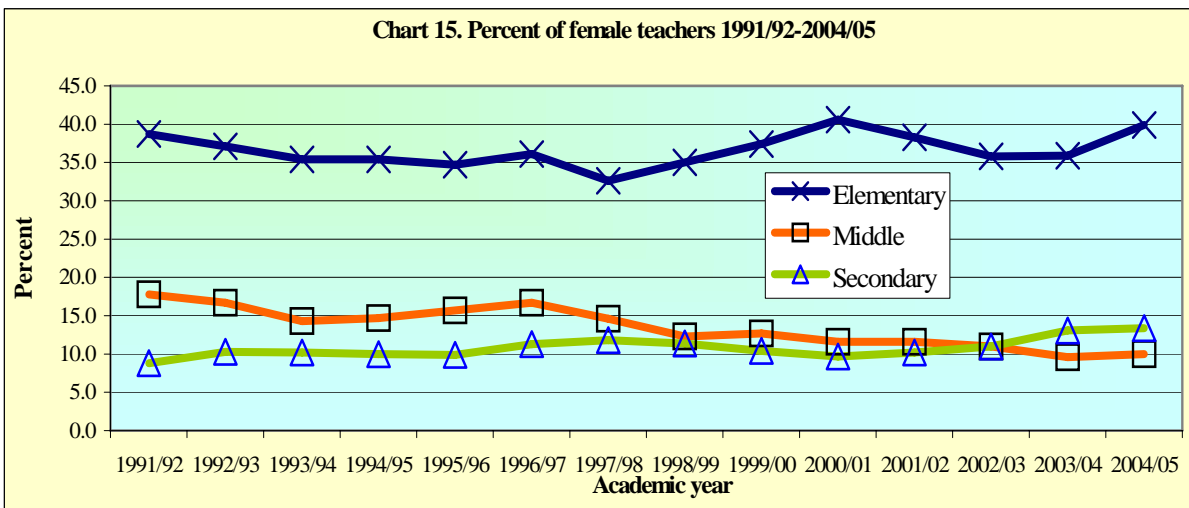

X. Age-specific enrolment 2004/05

Table 44. Age-specific enrolment 2004/05

| Age | School Age population | | Pre-primary | | Elementary | | Middle | | Secondary | | Enrolment % | |
|--------------|-----------------------|---------------|--------------|--------------|---------------|---------------|---------------|--------------|--------------|--------------|-------------|--------|
| | Total | Female | Total | Female | Total | Female | Total | Female | Total | Female | Total | Female |
| 0 | 96128 | 47113 | | | | | | | | | | |
| 1 | 84237 | 40897 | | | | | | | | | | |
| 2 | 76246 | 36678 | | | | | | | | | | |
| 3 | 82557 | 39424 | 692 | 342 | | | | | | | 0.8 | 0.9 |
| 4 | 88219 | 42002 | 7428 | 3774 | | | | | | | 8.4 | 9.0 |
| 5 | 93385 | 44463 | 12513 | 6246 | 85 | 36 | | | | | 13.5 | 14.1 |
| 6 | 97983 | 46753 | 9654 | 4823 | 15435 | 7394 | | | | | 16.7 | 16.8 |
| 5-6 | 191368 | 91216 | 22167 | 11069 | | | | | | | | |
| 7 | 102181 | 48931 | 884 | 449 | 47429 | 22421 | | | | | 46.5 | 45.9 |
| 8 | 106077 | 51020 | 73 | 45 | 58382 | 27201 | | | | | 55.0 | 53.3 |
| 9 | 107826 | 52138 | | | 61866 | 28606 | | | | | 57.4 | 54.9 |
| 10 | 106690 | 51915 | | | 59871 | 26881 | 194 | 104 | | | 56.3 | 52.0 |
| 11 | 103492 | 50715 | | | 49267 | 21790 | 3818 | 1861 | | | 51.3 | 46.6 |
| 7-11 | 526266 | 254719 | | | 276815 | 126899 | | | | | | |
| 12 | 99949 | 49387 | | | 34942 | 14618 | 11984 | 5521 | 2 | 1 | 47.0 | 40.8 |
| 13 | 95856 | 47878 | | | 24173 | 9969 | 20859 | 9234 | 234 | 127 | 47.2 | 40.4 |
| 14 | 91324 | 45889 | | | 14313 | 5481 | 27480 | 11689 | 1887 | 943 | 47.8 | 39.5 |
| 12-14 | 287129 | 143154 | | | | | 60323 | 26444 | | | | |
| 15 | 86626 | 43392 | | | 7256 | 2217 | 26053 | 10577 | 5702 | 2569 | 45.0 | 35.4 |
| 16 | 81768 | 40568 | | | 2920 | 652 | 20419 | 7568 | 9999 | 4316 | 40.8 | 30.9 |
| 17 | 76634 | 37662 | | | 988 | 126 | 13284 | 4217 | 12815 | 5228 | 35.3 | 25.4 |
| 18 | 71434 | 34673 | | | | | 7947 | 2034 | 13007 | 4708 | 29.3 | 19.4 |
| 15-18 | 316462 | 156295 | | | | | | | 41523 | 16821 | | |
| 19 | 66133 | 31945 | | | | | 3977 | 812 | | | | |
| 20 | 60764 | 29689 | | | | | | | | | | |
| 21 | 55560 | 27831 | | | | | | | | | | |
| 22 | 50453 | 25943 | | | | | | | | | | |
| 23 | 45133 | 23942 | | | | | | | | | | |
| 24 | 41821 | 22829 | | | 585 | 59 | | | | | | |
| 25 | 41515 | 23007 | | | | | 3014 | 379 | 15991 | 4502 | | |
| 26 | 43102 | 23974 | | | | | | | | | | |
| 27 | 44621 | 24931 | | | | | | | | | | |
| 28 | 46637 | 26169 | | | | | | | | | | |
| 29 | 47234 | 26484 | | | | | | | | | | |
| 30 | 45315 | 25240 | | | | | | | | | | |
| | | | 31244 | 15679 | 377512 | 167451 | 139029 | 53996 | 59637 | 22394 | | |

Table 45. Education Recurrent Expenditure 2005

| Zoba | Elementary | Middle | Secondary | Technical | Higher Education | Boarding Schools | Adult Education | Admni.Cost of ZEO, MOE HQ | Total |
|----------------------|-----------------------|----------------------|----------------------|----------------------|-----------------------|----------------------|---------------------|---------------------------|-----------------------|
| 1. Zoba Anseba | 18,914,661.69 | 1,110,544.86 | 1,325,357.83 | 0.00 | 0.00 | 6,477,829.05 | 1,459,540.45 | 1,663,624.71 | 30,951,558.59 |
| 2. Zoba DKB* | 1,939,290.86 | 496,536.82 | 393,585.74 | 0.00 | 0.00 | 4,046,735.79 | 247,848.67 | 1,083,610.26 | 8,207,608.14 |
| 3. Zoba Debub | 50,797,741.21 | 4,603,504.21 | 4,197,540.95 | 0.00 | 0.00 | 7,358,783.31 | 1,768,651.81 | 3,560,098.37 | 72,286,319.86 |
| 4. Zoba Gash Barka | 25,324,136.27 | 915,990.04 | 2,205,763.20 | 0.00 | 0.00 | 5,322,781.19 | 2,798,796.41 | 1,968,812.53 | 38,536,279.64 |
| 5. Zoba Maekel | 36,314,946.85 | 7,590,261.67 | 12,185,673.04 | 0.00 | 0.00 | 1,652,944.55 | 349,610.08 | 3,332,026.17 | 61,425,462.36 |
| 6. Zoba SKB* | 9,817,075.55 | 688,929.92 | 1,087,715.24 | 0.00 | 0.00 | 9,645,250.00 | 1,017,450.00 | 1,660,477.39 | 23,916,898.10 |
| 7. Sudan | 2,959,178.97 | 0.00 | 0.00 | 0.00 | 0.00 | 0.00 | 0.00 | 0.00 | 2,959,178.97 |
| 8. Warsay Ykealo | 0.00 | 0.00 | 18,550,734.16 | 0.00 | 0.00 | 0.00 | 0.00 | 0.00 | 18,550,734.16 |
| 9. TVET | 0.00 | 0.00 | 0.00 | 14,648,310.86 | 0.00 | 0.00 | 0.00 | 0.00 | 14,648,310.86 |
| 10. Higher Education | 0.00 | 0.00 | 0.00 | 0.00 | 282,246,730.61 | 0.00 | 0.00 | 0.00 | 282,246,730.61 |
| 11. ATTI | 0.00 | 0.00 | 0.00 | 0.00 | 3,534,099.05 | 0.00 | 0.00 | 0.00 | 3,534,099.05 |
| 12. MOE HQ | 0.00 | 0.00 | 0.00 | 0.00 | 0.00 | 0.00 | 0.00 | 26,100,319.04 | 26,100,319.04 |
| Total | 146,067,031.40 | 15,405,767.52 | 39,946,370.16 | 14,648,310.86 | 285,780,829.66 | 34,504,323.89 | 7,641,897.42 | 39,368,968.47 | 583,363,499.38 |

* DKB - Debubawi Keih Bahri

SKB - Semenawi Keih Bahri

Chart 16. Education Recurrent Expenditure 2005

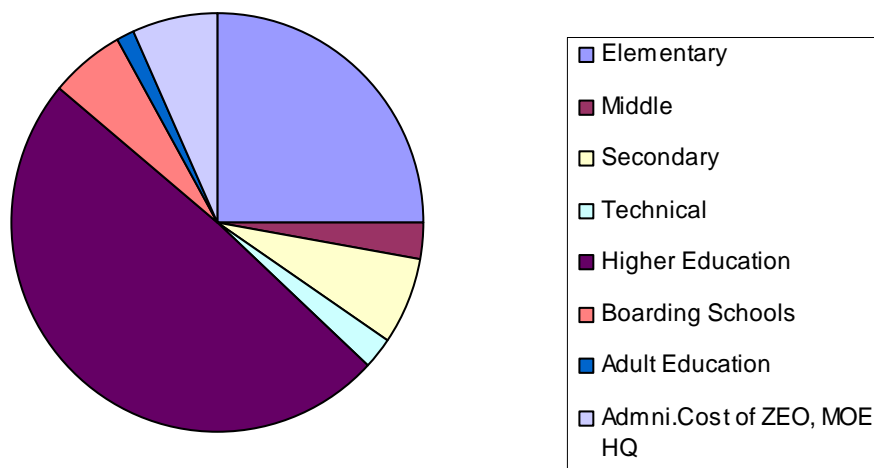
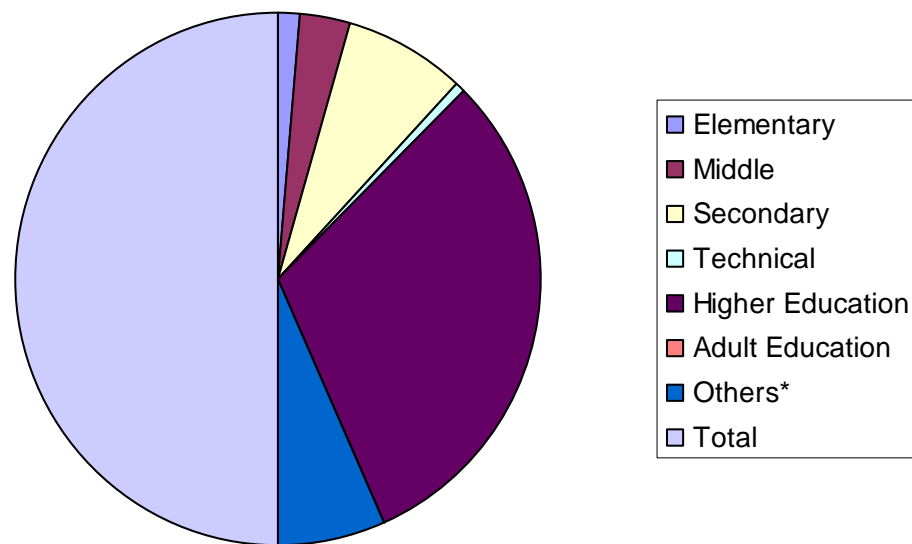

Chart 17. Education Capital Expenditure-2005



2. Capital Expenditure 2005

| | |
|------------------|-----------------------|
| Elementary | 7,004,659.14 |
| Middle | 15,508,478.10 |
| Secondary | 37,619,294.99 |
| Technical | 2,133,939.50 |
| Higher Education | 154,857,921.30 |
| Adult Education | 510,633.23 |
| Others* | 33,360,581.55 |
| Total | 250,995,507.81 |

Others*

| | |
|---------------------------------|----------------------|
| Summer Work Program | 19,390,761.00 |
| Curriculum Development | 3,187,620.15 |
| Cultural Activities | 302,484.80 |
| Capacity Building | 6,741,225.62 |
| Strengthening the School System | 3,738,489.98 |
| Total | 33,360,581.55 |

3. Total Recurrent and Capital Expenditure 2005

| | |
|--------------|-----------------------|
| Recurrent | 583,363,499.38 |
| Capital | 250,995,507.81 |
| Total | 834,359,007.19 |

Chart 18. Recurrent and Capital Expenditure 2005

