

Eritrea:

Essential Education Indicators

2007/08



ERITREA: Administrative zobas

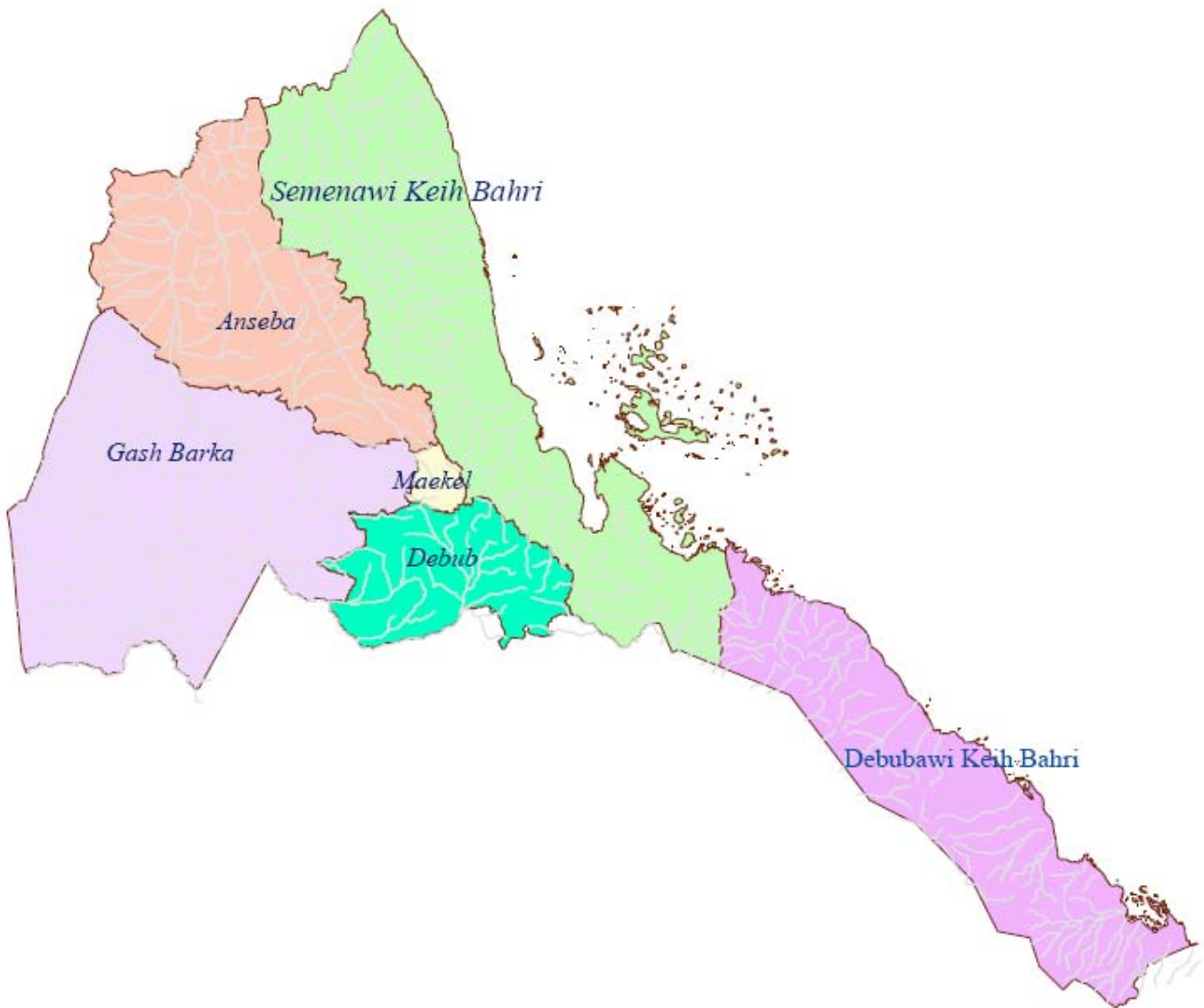

Ministry of Education
Asmara, Eritrea
December 2008

Table of contents

Contents	Page
I. Introduction and executive summary.....	1
1. Introduction	1
2. ExecutivesSummary	2
3. Data channels	3
II. Important notes.....	3
1. Population	3
2. Area of the country	3
3. School system	4
4. Gross dependency ratio	4
5. Definitions	4
III. Introductory information.....	5
IV. Pre-primary level.....	7
1. Pre-primary schools	7
2. Pre-primary enrolment	7
3. Pre-primary teachers	9
V. Elementary level.....	10
1. Duration	10
2. Enrolment	10
3. Gross admission ratio	11
4. Net admission ratio	12
5. Over-age pupils in grade one	13
6. Under-age pupils in grade one	13
7. Children out of school	14
8. Gross enrolment ratio	15
9. Net enrolment ratio by zoba	16
10. Elementary level: Percentage of repeaters	17
11. Disparities among the zobas	17
VI. Middle level.....	18
1. Duration	18
2. Enrolment	18
3. Gross enrolment ratio	19
4. Net enrolment ratio	20
5. Percentage of repeaters	21
VII. Secondary level.....	21
1. Duration	21
2. Enrolment	21
3. Gross enrolment ratio	22
4. Net enrolment ratio	23
5. Percentage of repeaters	24
VII. Internal efficiency.....	25
1. Length of school year	25
2. All grades flow rate	25
3. Elementary level: Flow rate by age, grade and gender	26
4. Middle level: Flow rate by age, grade and gender	28
5. Secondary level: Flow rates by age, grade and gender	29
6. Elementary level: Zobas flow rates	30
7. Elementary level: Cohort reconstruction – Eritrea and zobas	31

Content	Page
IX Teaching staff: Elementary, middle and secondary level	33
1. Pupil/teachers ratio: Elementary, middle and secondary level.	33
2. Teachers' qualification	33
3. Female teachers	34
X Age-Specific Enrolment 2007/08.....	35

Charts and figures

Chart 1. Pre-primary: Enrolment by year and gender.....	8
Chart 2. Elementary level: Enrolment by zoba and gender.....	11
Chart 3. Elementary level Gross and net admission ratio.....	12
Chart 4. Elementary level: Enrolment by year and gender.....	14
Chart 5. Elementary level: Gross enrolment ratio by year.....	15
Chart 6. Elementary level: Net enrolment ratio by year.....	16
Chart 7. Elementary level: Gross enrolment ratio by zoba	17
Chart 8. Middle level: Enrolment by zoba and gender.....	18
Chart 9. Middle level: Enrolment by year and gender.....	19
Chart 10. Secondary level: Enrolment by zoba and gender.....	22
Chart 11. Secondary level: Enrolment by year and gender.....	23
Chart 12. Secondary level: GER and NER by gender and year.....	24
Figure 1. Elementary level: Hypothetical cohort reconstruction (constant) – Eritrea...	31
Chart 13. Elementary level: Average length of study per student (ALSS) by zoba...	32
Chart 14. Percentage of wastage due to dropout and repetition by zoba.....	32

Tables

Table 1. Enrolment by level and gender 1991/92-2007/08.....	5
Table 2. Number of teachers by level and gender 1991/92-2007/08.....	6
Table 3. Non-government enrolment as percentage of total enrolment, 1991/92-2007/08	7
Table 4. Pre-primary level: Location and ownership by zoba, 2007/08.....	7
Table 5. Pre-primary level: Age-group and gross enrolment ratio, 1991/92-2007/08.	8
Table 6. Pre-primary level: Age-group and net enrolment ratio 2007/08.....	8
Table 7. Pre-primary level: Teachers and training status by zoba, 2007/08.....	9
Table 8. Pre-primary level: Pupil/teacher ratio 1991/92-2007/08.....	9
Table 9. Pre-primary level: Percentage of female teachers 1991/92-2007/08	10
Table 10. Elementary level: Enrolment by zoba and gender, 2007/08	10
Table 11. Elementary level: Gross admission ratio 1991/92-2007/08.....	11
Table 12. Elementary level: Net admission ratio 1991/92-2007/08.....	12
Table 13. Elementary level: Enrolment and percentage of over-age pupils in grade one	13
Table 14. Elementary level: Enrolment and percentage of under-age pupils in grade one	13
Table 15. Elementary level: Net enrolment and children out of school 1991/92-2007/08	14
Table 16. Elementary level: Gross enrolment ratio 1991/92-2007/08.....	15
Table 17. Elementary level: Net enrolment and net enrolment ratio 1991/92-2007/08.....	16
Table 18. Elementary level: Enrolment, repeaters and percentage of repeaters by gender 1991/92-2007/08.....	17
Table 19. Elementary level: Gross enrolment ratio and deviation from national ratio by zoba	17
Table 20. Elementary level: Net enrolment and deviation from national ratio by zoba.....	18
Table 21. Middle level: Enrolment by grade, gender and zoba (Gov. and non gov.) 2007/08	18
Table 22. Middle level: Gross enrolment ratio, 1991/92-2007/08.....	19
Table 23. Middle level: Gross enrolment ratio and deviation from national ratio by zoba 2007/08.....	20
Table 24. Middle level: Net enrolment ratio 1991/92-2007/08.....	20
Table 25. Middle level: Net enrolment ratio by zoba, 2007/08.....	20
Table 26. Middle level: Total number and percentage of repeaters 1991/92-2007/08.....	21
Table 27. Secondary level: Enrolment by gender and zoba (Gov. and non-gov.) 2007/08...	21
Table 28. Secondary level: Gross enrolment ratio 1991/92-2007/08.....	22

Content	Page
Table 29. Secondary level: Gross enrolment ratio by zoba, 2007/08.....	22
Table 30. Secondary level: Net enrolment ratio: 1991/92-2007/08.....	23
Table 31. Secondary level: Net enrolment ratio by zoba, 2007/08.....	23
Table 32. Secondary level: Number and percentage of repeaters by zoba 1991/92-2007/08	24
Table 33. Elementary level: Duration of school year, 2007/08.....	25
Table 34. All grades: Flow rates by gender and grade 2007/08.....	25
Table 35. Elementary level: Flow rate by age, grade and gender, 2007/08.....	26
Table 36. Middle level: Flow rate by age, grade and gender, 2007/08.....	28
Table 37. Secondary level: Flow rate by age, grade and gender 2007/08.....	29
Table 38. Elementary level: Average flow rate 2007/08.....	30
Table 39. Eritrea elementary level: Wastage, survival and transition ratios by Zoba.....	32
Table 40. Teachers: Gender and level by zoba, 2007/08.....	33
Table 41. Pupil/teacher ratio by year and level, 2007/08.....	33
Table 42. Teachers' qualifications, 2007/08.....	34
Table 43. Number and percentage of female teachers by level 1991/92-2007/08.....	34
Table 44. Age-specific enrolment 2007/08.....	35

I. Introduction and executive summary

1 Introduction

‘Eritrea: Essential Education Indicators is the official, annual education publication of the Ministry of Education (MoE) dealing with basic essential indicators. It is the 12th report produced by the Department of Research and Human Resource Development in terms of organization of schools in the new six administrative zobas, the Zobas. The sources of information for this publication are annual school censuses carried out by Zobas education offices through standard questionnaires from each school.

This publication covers data from Early Childhood Education (ECD) and General Education (Elementary, Middle and Secondary level). The main purpose of the 2007/08 publication is to provide relevant, reliable and up-to-date information on education. It will also serve as a source of useful information for the various stakeholders within and outside the education sector.

The MoE believes that the data presented in this publication is by no means considered exhaustive. For further inclusion and refinement to be made, the Ministry of Education is working to improve the quality and coverage of the education statistics. Moreover, continuous efforts will be made to produce better and timely information.

This publication would not have been possible without the contribution of the six Zoba education offices and other educational institutions. We remain deeply indebted to all for the efforts made in order to successfully finalize this publication.

We truly appreciate UNICEF: Eritrea office for its support in financing the printing of such publications. We also extend our appreciation to all those who provide us feedback and other relevant input.

Please feel free to give us your serviceable feedback regarding the content and form of this education abstract so that we will be able to attend to your requirements.

Department of Research and HRD
Ministry of Education
Asmara

December 2008

2. Executive summary

In the academic year 2007/08, enrolment in elementary level decreased by 5.4 percent and a decrease in enrolment in this level is observed all over where as enrolment in middle and secondary levels increased by 2.1 percent and 10.1 percent respectively as compared to previous academic year. An increase in enrolment in these levels is observed all over except in Maekel and Sawa zobas.

In the academic year 2007/08 enrolment of girls in elementary education in Eritrea decreased by 6.0 percent nationwide and 6.4 percent in government schools as compared to the academic year 2006/07.

As compared to the academic year 2006/07, the national enrolment of girls and boys in the academic year 2007/08 decreased by 1.4 and 1.3 percent respectively. The participation ratio of girls is still lower than that of boys except in literacy programmes, which is 88.6 percent. The gross enrolment ratio of females in pre-primary, elementary, middle and secondary levels were 21.5 percent, 62.8 percent 38.4 percent and 18.3 percent respectively.

The number of schools, students in pre-primary education has decreased by 1.3 percent, and 4.0 percent respectively, but the number of teacher remains unchanged. The number of schools by level in elementary, middle and secondary school levels increased by 1.7, 9.9 and 15.8 percent respectively. The number of teachers in elementary, middle and secondary levels increased by 5.4, 9.1 and 1.8 percent respectively.

The gross national accessibility to schooling in 2007/08 was about 21.3 percent, 67.1 percent, 44.7 percent and 22.4 percent in pre-primary, elementary, middle and secondary education respectively.

This and subsequent sections show the overall situation of the education system at all levels. The information also includes developments since 1991.

3 Data channels

The information in this statistical abstract is gathered mainly from Questionnaires: number 7, 8 and 9. The first two are closed questionnaires, in which schools and institutions send back the *November data* on Pre-primary, Elementary, Middle, and Secondary schools to the MoE. The expected time of completion, of these questionnaires is April. In every academic year normally 100% of the questionnaires are collected.

Questionnaire item 9 covers a school's physical, financial and internal efficiency particulars. The expected time of completion of this Questionnaire is July, after the end of each academic year.

We assure users of this abstract that all necessary measures have been taken to make the information provided in this issue valuable and reliable.

Data in all tables, unless otherwise stated, refer to the academic year 2007/08. Table numbers are sub-grouped under corresponding sections. Charts are sequenced in a continuous ascending order throughout the abstract.

II. Important notes

1. Population

- 1.1 For the purpose of this issue, the mid-variant of the 2007 population estimate 3,735,560 is used to derive essential educational indicators; it is also used in splitting the population into single age population.

We would like to remind users of our yearly abstracts that we have been using different population estimation in our previous publications. We have used the new population estimation, which is considered to be a better estimation, as a base to calculate school-age population and thus enrolment and other essential indicators as well.

- 1.2. Average **population density**: 28/sq.km.

- 1.3. Total **school-age population** by school level (estimated percentage of the total population for the year 2007).

Age group	Population	Estimated % of total population
5-6	168,324	4.51
7-11	468,165	12.53
12-14	322,062	8.62
15-18	373,008	9.98

2. **Area of the country**: approximately **124,000 sq. km.**

3. School system

Level	Grade	Age
Pre-school	I, II	5-6
Elementary	1-5	7-11
Middle	6-8	12-14
Secondary	9-12	15-18

4. Gross Dependency Ratio defined as percentage of the sum of all persons under 15 years and over 64 years divided by the number of persons age 15-64.

Age-group	Population	Dependency ratio	
0-5 years	661,269	32.92	Young dependency ratio
6-14 years	873,741	43.50	Young dependency ratio
65 years and above	192,019	9.56	Old dependency ratio

Total dependants (estimate)	1,727,029
Total non-dependants (estimate)	2,008,531
Gross Dependency Ratio	85.98

5. Definitions

5.1 Government schools are schools administered and financed by the Ministry of Education.

5.2 Non-government schools are schools administered and financed by institutions other than the Ministry of Education.

• **Types of non.gov schools are:-**

5.2.1. Domestic Community schools are schools administered by municipalities or local communities

5.2.2. Foreign Community schools are schools administered by foreign communities (Italian etc. communities).

5.2.3. Awkaf (Mahad) schools are schools administered by Awkaf (Islamic religion association).

5.2.4. Mission schools are schools administered by churches (Coptic, Catholic, and Protestant churches).

5.3 Special schools are schools for the deaf and the blind. There are two schools for the deaf, one in Keren and another in Asmara and one school for the blind in Asmara.

5.4 Number of schools by level:

A school having grades 1-11(12) is considered as three (1-5, 6-8, 9-12) schools by **level** regardless of being single **site**; another having grades 1-8 is considered as two schools as it contains two levels (1-5 and 6-8) and the same for schools having grades 6-12.

5.5. Number of schools by site:

One single school compound or **site** may accommodate a combination of two or three level of schools but may be counted as one school **for purposes of specific location**. The number of schools by level is always greater than the number of schools by site.

III. Introductory information

Tables 1 and 2 give the number of students and teachers of general education, TTI and Technical and vocational schools since 1991/92.

Table 1: Enrolment by level and gender 1991/92-2007/08

Year	Elementary		Middle		Secondary		TTI		Tech. and voc		Total	
	F	T	F	T	F	T	F	T	F	T	F	T
1991/92	69,324	150,870	13,765	27,917	13,183	27,627	290	1,268	61	480	96,273	208,274
1992/93	82,356	184,492	13,375	28,427	14,390	31,531	720	2,580	58	537	110,964	247,731
1993/94	92,536	208,199	14,652	32,781	13,324	32,756	54	398	60	589	120,626	274,723
1994/95	99,743	224,287	15,685	34,995	14,631	36,728	674	2,185	53	546	130,786	298,741
1995/96	108,254	241,725	18,103	39,751	15,475	39,151	9	93	59	536	141,900	321,256
1996/97	108,487	240,737	20,721	47,460	16,332	40,594	52	359	71	546	145,663	329,696
1997/98	111,930	247,499	24,154	57,152	16,417	41,615	87	478	69	406	152,657	347,150
1998/99	118,385	261,963	29,290	67,021	17,756	47,533	73	471	140	908	165,644	377,896
1999/00	133,045	295,941	33,284	74,317	22,093	59,626	129	606	147	1,018	188,698	431,508
2000/01	134,168	298,691	35,107	76,564	23,596	63,951	197	961	464	1,866	193,532	442,033
2001/02	146,218	330,278	34,667	80,882	25,054	70,183	169	1,022	393	1,992	206,501	484,357
2002/03	159,563	359,423	36,881	87,019	26,185	72,818	61	874	429	1,965	223,119	522,099
2003/04	165,954	374,997	49,224	122,966	22,952	69,401	474	474	531	1,917	569,755	347,058
2004/05	167,451	377,512	53,996	139,029	26,041	76,051	365	492	675	1,152	248,528	594,236
2005/06	161,875	364,263	57,448	148,082	27,293	77,644	0	0	881	2,060	247,497	592,049
2006/07	149,755	331,855	59,342	141,081	30,329	75,800	102	646	685	1,488	240,213	550,870
2007/08	140,792	314,034	60,265	144,031	34,088	83,411	177	631	2,581	6,094	237,903	548,201

Table 2: Number of teachers by level and gender 1991/92-2007/08

Year	Elementary		Middle		Secondary		TTI		Tech. and voc		Total	
	F	T	F	T	F	T	F	T	F	T	F	T
1991/92	1,411	3,647	139	783	67	758	3	31	5	67	1,625	5,286
1992/93	1,841	4,954	143	854	93	905	6	87	4	75	2,087	6,875
1993/94	1,865	5,272	140	978	104	1,015	3	34	0	63	2,112	7,362
1994/95	1,974	5,583	139	948	108	1,081	3	44	2	74	2,226	7,730
1995/96	2,025	5,828	156	992	103	1,039	2	32	6	80	2,292	7,971
1996/97	1,977	5,476	170	1,017	106	942	6	33	1	79	2,260	7,547
1997/98	1,893	5,799	170	1,162	113	959	4	38	0	66	2,180	8,024
1998/99	1,951	5,576	149	1,208	112	982	3	38	4	101	2,219	7,905
1999/00	2,330	6,229	167	1,312	109	1,047	2	32	9	104	2,617	8,724
2000/01	2,710	6,668	160	1,377	115	1,188	11	37	9	173	3,005	9,443
2001/02	2,873	7,498	177	1,529	145	1,419	6	47	17	174	3,218	10,667
2002/03	2,756	7,692	178	1,614	140	1,277	5	46	69	265	3,148	10,894
2003/04	2,887	8,033	216	2,241	215	1,645	11	23	78	326	3,407	12,268
2004/05	3,166	7,942	245	2,449	215	1,609	4	25	16	169	3,646	12,194
2005/06	3,296	7,711	257	2,491	188	1,552	0	0	15	145	3,756	11,899
2006/07	3,305	6,933	245	2,478	208	1,778	12	41	10	169	3,780	11,399
2007/08	3,241	7,311	258	2,704	210	1,811	10	39	39	376	3,758	12,241

In elementary and middle levels only directors are included in teaching staff where as in secondary level directors and other staffs that is actively participated in teaching and learning process are included.

Table 3. Non-government enrolment as percentage of total enrolment 1991/92-2007/08

Year	1- 5			6 – 7			8 – 11		
	Non-gov.	T	%	Non-gov.	T	%	Non-gov.	T	%
1991/92	33,377	150,870	22.1	4,788	27,917	17.2	794	27,627	2.9
1992/93	31,513	184,492	17.1	5,174	28,427	18.2	1,740	31,531	5.5
1993/94	31,766	208,199	15.3	5,203	32,781	15.9	1,984	32,756	6.1
1994/95	30,398	224,287	13.6	4,992	34,995	14.3	2,530	36,728	6.9
1995/96	30,650	241,725	12.7	5,385	39,751	13.5	3,514	39,151	9.0
1996/97	29,578	240,737	12.3	5,841	47,460	12.3	3,313	40,594	8.2
1997/98	27,292	247,499	11.0	5,401	57,152	9.5	2,634	41,615	6.3
1998/99	29,153	261,963	11.1	5,417	67,021	8.1	2,094	47,533	4.4
1999/00	29,766	295,941	10.1	5,155	74,317	6.9	2,292	59,626	3.8
2000/01	27,860	298,691	9.3	5,598	76,564	7.3	2,591	63,951	4.1
2001/02	27,269	330,278	8.3	5,758	80,882	7.1	2,672	70,183	3.8
2002/03	28,570	359,423	7.9	6,201	87,019	7.1	2,761	72,818	3.8
	1- 5			6 – 8			9-12		
2003/04	29,134	374,997	7.8	8,933	122,966	7.3	2,630	69,401	3.8
2004/05	29,862	377,512	7.9	9,422	139,029	6.8	2,701	76,051	3.6
2005/06	29,728	364,263	6.6	9,458	148,082	4.1	2,401	77,644	3.1
2006/07	29,070	331,855	8.8	9,492	141,081	6.7	1,497	75,800	2.0
2007/08	28,482	314,034	9.1	10,460	144,031	7.3	2,351	83,411	2.8

IV. Pre-primary level

1. Pre-primary schools

In the academic year 2007/08, there were 471 pre-primary schools in the whole country. 120 (25.5%) of them are located in Zoba Maekel. Out of which 55 (45.8%) are located in Asmara, the capital city.

In the academic year 2007/08, 342 (72.6%) out of the 471 schools were government owned, while the rest of the schools, 129 (27.4%) were non-government owned.

Table 4. Pre-primary level: Location and ownership by zoba, 2007/08

Zoba	Ownership												
	Total			Government		Mission		Awkaf		Private		Community	
	Tot	Urb	Rur	Urb	Rur	Urb	Rur	Urb	Rur	Urb	Rur	Urb	Rur
Anseba	75	16	59	10	52	5	3	0	0	0	0	3	2
Debub	139	19	120	9	94	10	7	0	0	1	3	2	13
Deb-Keih-B.	23	4	19	4	18	1	0	0	0	0	0	0	0
Gash Barka	73	25	48	22	48	0	3	0	0	0	0	0	0
Maekel	120	57	63	4	47	4	14	2	0	19	2	18	10
Sem-Keih-B.	41	17	24	11	23	1	5	0	0	1	0	0	0
Total	471	138	333	60	282	21	32	2	0	21	5	23	25

N.B. Urb = Urban Rur = Rural

2. Pre-primary enrolment

Children of ages 5 and 6 are enrolled in pre-primary education, and the gross enrolment ratio has gradually been increasing from 4.3% in 1991/92 and has reached 22.0% in 2006/07. The gross enrolment ratio of the academic year 2007/08 has decreased by 0.7% from the previous academic year.

Table 5. Pre-primary level: Age-group and gross enrolment ratio, 1991/92-2007/08

Year	Population age-group 5-6			Enrolment in pre-primary			Gross enrolment ratio		
	T	M	F	T	M	F	T	M	F
1991/92	151,758	80,047	71,711	6,461	3,142	3,319	4.3	3.9	4.6
1992/93	157,155	83,071	74,084	7,031	3,426	3,605	4.5	4.1	4.9
1993/94	162,451	85,871	76,580	7,748	3,909	3,839	4.8	4.6	5.0
1994/95	167,681	88,493	79,188	8,032	4,102	3,930	4.79	4.6	5.0
1995/96	172,869	90,974	81,895	8,180	4,201	3,979	4.7	4.6	4.9
1996/97	178,026	93,344	84,682	7,443	3,791	3,652	4.2	4.1	4.3
1997/98	182,438	95,262	87,176	9,300	4,683	4,617	5.1	4.9	5.3
1998/99	193,506	100,775	92,731	11,581	6,168	5,413	6.0	6.1	5.8
1999/00	194,782	101,380	93,402	11,885	6,181	5,704	6.1	6.1	6.1
2000/01	201,401	104,926	96,475	12,436	6,540	5,896	6.2	6.2	6.1
2001/02	208,703	108,972	99,731	12,747	6,704	6,043	6.1	6.2	5.6
2002/03	211,624	110,141	101,483	14,958	7,563	7,395	7.1	6.9	7.3
2003/04	203,602	106,339	97,263	18,540	9,821	8,719	9.1	9.2	9.0
2004/05	191,368	91,216	100,152	31,244	15,565	15,679	16.3	17.1	15.7
2005/06	178,548	93,457	85,091	35,569	17,672	17,897	19.9	18.9	21.0
2006/07	169,078	88,291	80,787	37,263	19,147	18,116	22.0	21.7	22.4
2007/08	168,324	87,437	80,887	35,833	18,442	17,391	21.3	21.1	21.5

Table 6. Pre-primary: Age-group and net enrolment ratio in 1999/2000-2007/08

Year	Population age-group 5-6			Net enrolment in pre-primary			Net enrolment ratio		
	T	M	F	T	M	F	T	M	F
1999/00	194,782	101,380	93,402	9,471	4,907	4,564	4.9	4.8	4.9
2000/01	201,401	104,926	96,475	8,898	4,684	4,214	4.4	4.5	4.4
2001/02	208,703	108,972	99,731	9,160	4,828	4,332	4.4	4.4	4.3
2002/03	211,624	110,141	101,483	10,605	5,266	5,339	5.0	4.9	5.3
2003/04	203,602	106,339	97,263	13,189	6,826	6,363	6.5	6.4	6.5
2004/05	191,368	91,216	100,152	22,167	11,098	11,069	11.6	12.2	11.1
2005/06	178,548	93,457	85,091	25,052	12,294	12,758	14.0	13.2	15.0
2006/07	169,078	88,291	80,787	24,993	12,864	12,129	14.9	14.6	15.0
2007/08	168,324	87,437	80,887	24,597	12,686	11,911	14.6	14.5	14.7

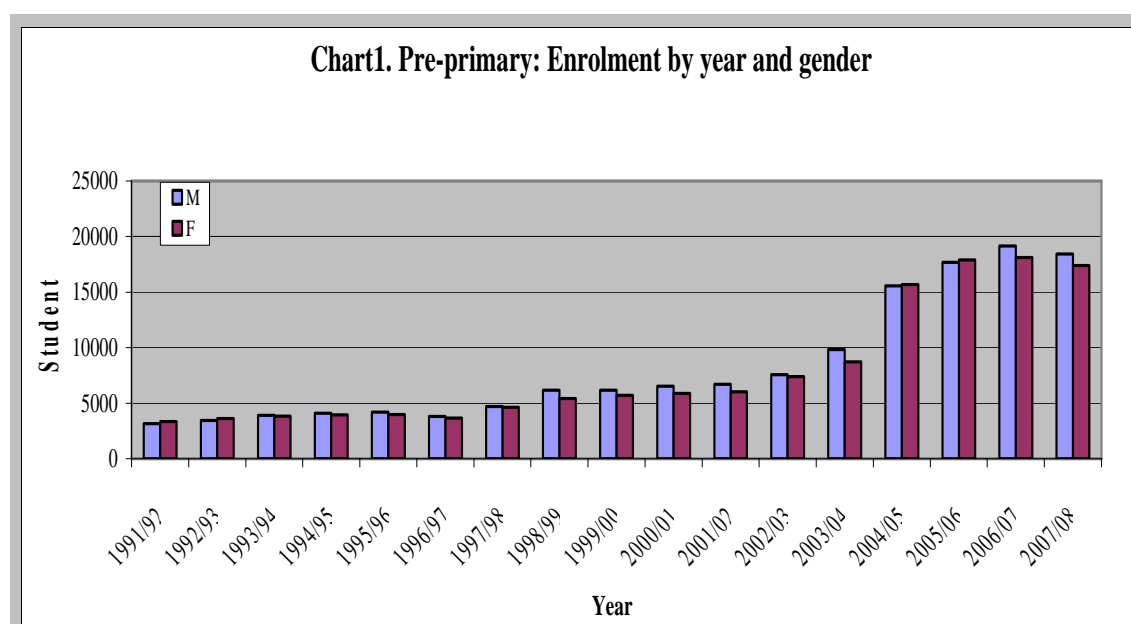

3. Pre-primary teachers

During the academic year 2007/08, there were 1,062 pre-primary teachers in the whole country of whom 635 (59.97%) have professional training. And 401 females and 15 male teachers were without any professional training.

As table 7 indicates almost all (1,025 or 96.51%) teachers in pre-primary schools are female. The percentage of male teachers is fluctuating between 0 and 4 percent from 1991/92 up to the current academic year.

Table 7. Pre-primary level: Teachers and training status by zoba, 2007/08

Zoba	Total		Trained		Not trained	
	T	F	T	F	T	F
Anseba	144	136	76	71	68	65
Debub	247	242	168	163	79	79
Deb-Keih-B	33	27	15	10	18	17
Gash-Barka	122	120	90	89	32	31
Maekel	438	427	245	243	193	184
Sem-Keih-B	78	73	41	37	37	36
Total	1,062	1,025	635	613	427	412

Table 8. Pre-primary level: Pupil/teacher ratio 1991/92-2007/08

Year	Enrolment			Teachers			Pupil/teacher ratio
	T	M	F	T	M	F	
1991/92	6,461	3,142	3,319	201	0	201	32
1992/93	7,031	3,426	3,605	227	0	227	31
1993/94	7,748	3,909	3,839	244	1	243	32
1994/95	8,032	4,102	3,930	256	1	255	31
1995/96	8,180	4,201	3,979	235	3	232	35
1996/97	7,443	3,791	3,652	207	3	204	36
1997/98	9,300	4,683	4,617	239	3	236	39
1998/99	11,581	6,168	5,413	321	9	312	36
1999/00	11,885	6,181	5,704	320	6	314	37
2000/01	12,436	6,540	5,896	326	8	318	38
2001/02	12,747	6,704	6,043	353	6	347	37
2002/03	14,958	7,563	7,395	410	19	391	37
2003/04	18,540	9,821	8,719	492	21	471	38
2004/05	31,244	15,565	15,679	845	29	816	37
2005/06	35,569	17,672	17,897	1,030	39	991	35
2006/07	37,263	19,147	18,116	1,067	33	1,034	35
2007/08	35,833	17,391	18,442	1,062	37	1,025	34

In pr-primary level directors are included in teaching staff

Table 9. Pre-primary: Percentage of female teachers 1991/92-2007/08

Year	Teachers			% of female teachers
	T	M	F	
1991/92	201	0	201	100.0
1992/93	227	0	227	100.0
1993/94	244	1	243	99.6
1994/95	256	1	255	99.6
1995/96	235	3	232	98.7
1996/97	207	3	204	98.6
1997/98	239	3	236	98.7
1998/99	321	9	312	97.2
1999/00	320	6	314	98.1
2000/01	326	8	318	97.5
2001/02	353	6	347	98.3
2002/03	413	19	394	95.4
2003/04	492	21	471	95.7
2004/05	845	29	816	96.6
2005/06	1,030	39	991	96.2
2006/07	1,067	33	1,034	96.9
2007/08	1,062	37	1,025	96.5

V. Elementary level

1. Duration

In this level, children of ages 7-11 are enrolled from grades 1-5. Education in this level is free of charge and compulsory. At this level, language of instruction is mother tongue.

2. Enrolment

Enrolment in this level for the academic year 2007/08 is 314,034 out of which 140,792 (44.83%) were females. Out of the total enrolment in elementary school, 28,482 (9.07%) were enrolled in non-government schools.

Table 10. Elementary level: Enrolment by zoba and gender, 2007/08

Zoba	2006/07			2007/08		
	T	M	F	T	M	F
Anseba	50,251	28,136	22,115	47,684	26,849	20,835
Debub	117,241	62,643	54,598	111,401	60,504	50,897
Deb-Keih-B.	4,169	2,834	1,335	4,072	2,765	1,307
Gash-Barka	66,131	37,167	28,964	61,605	34,489	27,116
Mackel	67,067	35,151	31,916	64,434	33,753	30,581
Sem-Keih-B.	26,996	16,169	10,827	24,838	14,782	10,056
Total	331,855	182,100	149,755	314,034	173,142	140,792

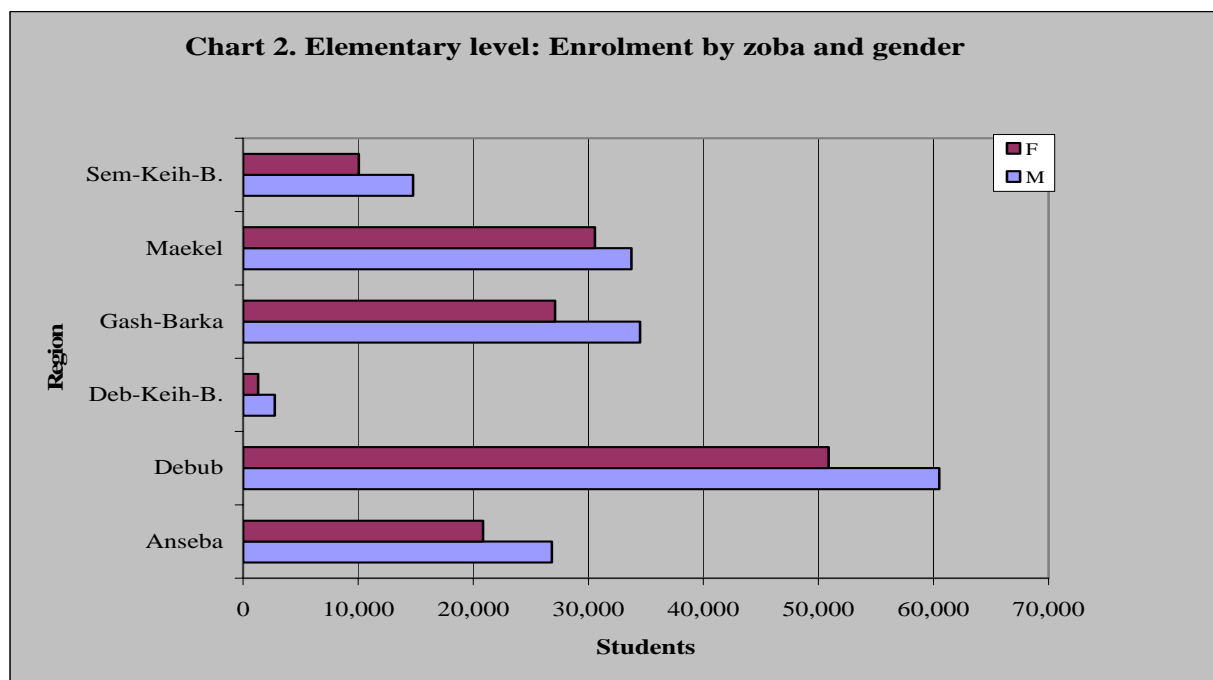

3. Gross admission ratio

Table 11. Elementary level: Gross admission ratio, 1991/92-2007/08

Year	Population of age 7			Admission in grade one			Gross admission ratio		
	T	M	F	T	M	F	T	M	F
1991/92	76,409	40,250	36,159	46,671	25,807	20,864	61.1	64.1	57.7
1992/93	79,125	41,770	37,355	46,210	26,612	19,598	58.4	63.7	52.5
1993/94	81,793	43,179	38,614	45,656	25,432	20,224	55.8	58.9	52.4
1994/95	84,426	44,497	39,929	44,285	24,159	20,126	52.5	54.3	50.4
1995/96	87,038	45,745	41,293	46,497	26,108	20,389	53.4	57.1	49.4
1996/97	89,635	46,937	42,698	41,122	22,578	18,544	45.9	48.1	43.4
1997/98	91,857	47,901	43,956	50,471	28,407	22,064	55.0	59.3	50.2
1998/99	97,430	50,673	46,757	57,336	31,758	25,578	58.9	62.7	54.7
1999/00	98,147	50,689	47,458	68,902	38,345	30,557	70.2	75.7	64.4
2000/01	101,482	52,462	49,020	72,139	39,595	32,544	71.1	75.5	66.4
2001/02	105,158	54,484	50,674	74,899	41,114	33,785	71.2	75.5	66.7
2002/03	106,633	55,069	51,564	76,145	41,767	34,378	71.4	75.8	66.7
2003/04	103,616	52,494	51,122	68,983	38,059	30,924	66.6	72.5	60.5
2004/05	102,181	53,250	48,931	69,166	37,633	31,533	67.7	70.7	64.4
2005/06	96,020	50,169	45,851	60,922	32,985	27,937	63.5	65.8	60.9
2006/07	89,660	46,895	42,765	52,983	28,546	24,437	59.1	60.1	57.1
2007/08	84,740	44,270	40,470	51,784	28,326	23,458	61.1	64.0	58.0

As can be shown in Table 11, the gross admission ratio has been steadily decreasing from 61.1% to 45.9% between the academic year 1991/92 and 1996/97 (except for the academic year 1995/96). The gross admission ratio has been progressively increasing from 45.9% to 71.4% between the academic year 1996/97 and 2002/03 and then dropped down to 66.6% in the academic year 2003/04. The gross admission ratio has been decreasing continuously from 67.7% in the academic year 2004/05 and has reached 59.1% in the academic year 2006/07. In 2007/08 academic year gross admission ratio has increased by 2.0% as compared to the previous scholastic year.

4. Net admission ratio

Table 12. Elementary level: Net admission ratio, 1991/92-2007/08

Year	Population of age 7			Admission of age 7			Net admission ratio		
	T	M	F	T	M	F	T	M	F
1991/92	76,409	40,250	36,159	8,605	4,580	4,025	11.3	11.4	11.1
1992/93	79,125	41,770	37,355	N.A	NA	NA	N.A	N.A	N.A
1993/94	81,793	43,179	38,614	9,947	5,392	4,555	12.2	12.5	11.8
1994/95	84,426	44,497	39,929	11,227	5,949	5,278	13.3	13.4	13.2
1995/96	87,038	45,745	41,293	15,612	8,053	7,559	17.9	17.6	18.3
1996/97	89,635	46,937	42,698	15,469	8,132	7,337	17.3	17.3	17.2
1997/98	91,857	47,901	43,956	14,370	7,723	6,647	15.6	16.1	15.1
1998/99	97,430	50,673	46,757	18,140	9,608	8,532	18.6	19.0	18.3
1999/00	98,147	50,689	47,458	20,674	11,169	9,505	21.1	22.0	20.0
2000/01	101,482	52,462	49,020	32,977	17,632	15,345	32.5	33.6	31.3
2001/02	105,158	54,484	50,674	37,071	20,094	16,977	35.3	36.9	33.5
2002/03	106,633	55,069	51,564	33,199	17,810	15,389	31.1	32.3	30.7
2003/04	103,616	52,494	51,122	29,568	15,906	13,662	28.5	30.3	26.7
2004/05	102,181	53,250	48,931	29,866	15,833	14,033	29.2	29.7	28.7
2005/06	96,020	50,169	45,851	26,923	14,203	12,720	28.0	28.3	27.7
2006/07	89,660	46,895	42,765	22,577	12,145	10,432	25.2	25.9	24.4
2007/08	84,740	44,270	40,470	20,502	11,157	9,345	24.2	25.2	23.1

As can be seen from table 12, the net admission ratio has increased yearly between the successive academic years of 1991/92-2001/02 except in the academic year 1997/98, and in the academic year 2002/03 it has shown a drop off 4%, while from the academic year 2003/04 it has shown successive increments and has reached 29.2% in the academic year 2004/05. As shown above in table 12 the net admission has shown successive decrement between 2005/06 and 2007/08 academic year.

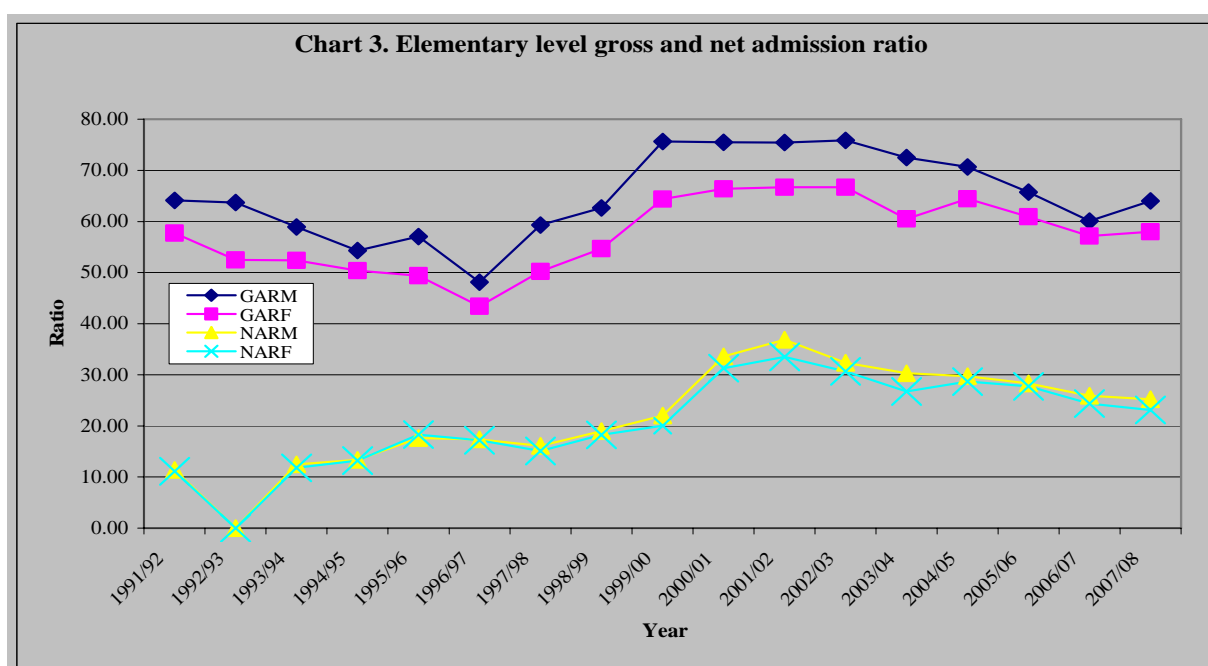

5. Over-aged pupils in grade one.

Table 13. Elementary level: Enrolment and percentage of over-age pupils in grade one, 1991/92-2007/08

Year	Enrolment in grade 1			Over-age enrolment in Grade 1			% of over-age in grade 1		
	T	M	F	T	M	F	T	M	F
1991/92	67,550	36,867	30,683	52,427	28,919	23,508	77.6	78.4	76.6
1992/93	68,770	38,291	30,479	N.A	NA	NA	NA	NA	NA
1993/94	64,527	35,101	29,426	48,963	26,886	22,075	75.9	76.6	75.0
1994/95	62,914	33,793	29,121	46,192	25,043	21,147	73.4	74.1	72.6
1995/96	65,110	34,869	30,241	47,320	25,600	21,718	72.7	73.4	71.8
1996/97	58,841	31,820	27,021	40,404	22,032	18,372	68.7	69.2	68.0
1997/98	68,388	38,104	30,284	48,649	27,496	21,153	71.1	72.2	69.8
1998/99	75,340	41,586	33,754	50,409	28,365	22,044	66.9	68.2	65.3
1999/00	91,037	50,459	40,576	59,351	33,493	25,858	65.2	66.4	63.7
2000/01	88,045	47,907	40,138	45,357	25,146	20,211	51.5	52.5	50.4
2001/02	97,678	53,409	44,269	48,885	27,137	21,748	50.0	50.9	49.1
2002/03	101,496	55,186	46,310	53,456	28,270	25,186	52.7	51.2	54.4
2003/04	99,216	54,309	44,907	46,542	26,229	20,313	46.9	48.3	45.2
2004/05	89,524	48,902	40,622	36,585	20,831	15,754	40.9	42.6	38.8
2005/06	73,222	39,781	33,441	27,184	15,534	11,650	37.1	39.1	34.8
2006/07	62,486	33,732	28,754	36,729	19,783	16,946	58.8	58.6	58.9
2007/08	60,940	33,506	27,434	16,086	9,275	6,811	26.4	27.7	24.8

Table 13 indicates that the percentage of over-aged pupils has been decreasing every academic year, except for the 1997/98, 2002/03 and 2006/07 academic years. So a relentless effort has to be made to decrease over-aged pupils in grade 1.

6. Under-aged pupils in grade one

Table 14. Elementary level: Enrolment and percentage of under-age pupils in grade one, 1991/92-2007/08

Year	Enrolment in Grade 1			Under-age enrolment grade1			Percentage of under-age		
	T	M	F	T	M	F	T	M	F
1991/92	67,550	36,867	30,683	2,661	1,405	1,256	3.9	3.8	4.1
1992/93	68,770	38,291	30,479	1,906	962	944	2.8	2.5	3.1
1993/94	64,527	35,101	29,426	1,527	778	749	2.3	2.2	2.5
1994/95	62,914	33,793	29,121	865	447	418	1.4	1.3	1.4
1995/96	65,110	34,869	30,241	880	445	435	1.4	1.3	1.4
1996/97	58,841	31,820	27,021	1,135	588	547	1.9	1.8	2.0
1997/98	68,388	38,104	30,284	1,186	637	549	1.7	1.7	1.8
1998/99	75,340	41,586	33,754	3,497	1,814	1,683	4.6	4.4	5.0
1999/00	91,037	50,459	40,576	6,295	3,294	3,001	6.9	6.5	7.4
2000/01	88,045	47,907	40,138	9,693	5,112	4,581	11.0	10.7	11.4
2001/02	97,678	53,409	44,269	11,722	6,178	5,544	12.0	11.6	12.5
2002/03	101,496	55,186	46,310	10,990	5,704	5,286	10.8	10.3	11.4
2003/04	99,216	54,309	44,907	13,682	7,062	6,620	13.8	13.0	14.7
2004/05	89,524	48,902	40,622	15,520	8,090	7,430	17.3	16.5	18.3
2005/06	73,222	39,781	33,441	14,492	7,423	7,069	19.8	18.7	21.1
2006/07	62,486	33,732	28,754	19,371	10,083	9,288	31.0	29.9	32.3
2007/08	60,940	33,506	27,434	20,349	10,821	9,528	33.4	32.3	34.7

From the academic year 1991/92 until the academic year 1997/98 except for the academic year 1996/97 enrolment of under-aged was continuously decreasing. This was mainly because MoE regulations in those years did not allow children under 7 to be enrolled in elementary schools. Starting from the academic year 1997/98 the enrolment of under-aged children has been increasing continuously except for the academic year 2002/03. This is because age 6 students are allowed to attend in grade 1.

7. Children out of school

Table 15. Enrolment level: Net enrolment and children out of school 1991/92-2007/08

Year	Population 7-11.			Net enrolment 7-11.			NER	Number of children out of school 7-11			Percentage of children out of School 7-11
	T	M	F	T	M	F		T	M	F	
1991/92	375,234	198,552	176,682	93,087	48,397	44,690	24.8	282,147	150,155	131,992	75.2
1992/93	388,581	206,052	182,529	109,111	57,126	51,985	28.1	279,470	148,926	130,544	71.9
1993/94	401,679	213,000	188,679	113,612	59,645	53,967	28.3	288,067	153,355	134,712	71.7
1994/95	414,606	219,502	195,104	122,084	64,098	57,986	29.5	292,522	155,404	137,118	70.5
1995/96	427,429	225,658	201,771	133,496	69,958	63,538	31.2	293,933	155,700	138,233	68.8
1996/97	440,171	231,537	208,634	136,943	72,073	64,870	31.1	303,228	159,464	143,764	68.9
1997/98	451,076	236,293	214,783	150,751	80,212	70,539	33.4	300,325	156,081	144,244	66.6
1998/99	478,441	249,970	228,471	166,879	89,556	77,323	34.9	311,562	160,414	151,148	65.1
1999/00	470,652	239,841	230,811	194,963	104,748	90,215	41.4	275,689	135,093	140,596	58.6
2000/01	486,639	248,232	238,407	205,831	111,022	94,809	42.3	280,808	137,210	143,598	57.7
2001/02	504,246	257,793	246,453	232,030	125,941	106,089	46.0	272,216	131,852	140,364	54.0
2002/03	511,350	260,568	250,782	256,360	139,072	117,288	40.1	255,012	121,510	133,502	49.9
2003/04	522,975	268,340	254,635	269,326	146,379	122,947	51.5	250,252	120,296	129,956	47.9
2004/05	526,266	271,547	254,719	276,815	149,916	126,899	52.6	245,439	119,584	125,855	46.6
2005/06	518,357	268,669	249,688	272,401	146,588	125,813	52.6	245,956	122,081	123,875	47.5
2006/07	497,762	258,858	238,904	248,782	133,238	115,544	50.0	248,980	125,620	123,360	50.0
2007/08	468,165	243,937	224,228	233,590	125,816	107,774	49.9	234,575	118,121	116,454	50.1

It can be clearly seen from the enrolment of pre-primary, over-age children are attending in the pre-primary level.

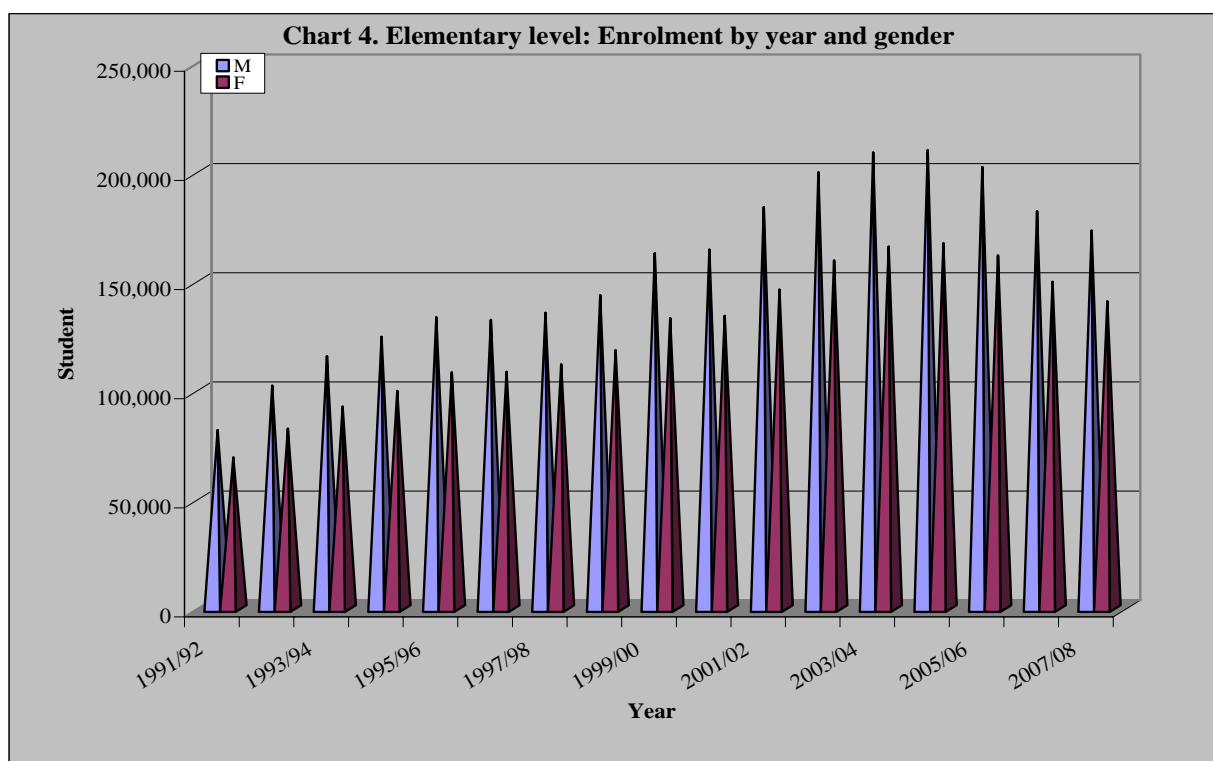

8. Gross enrolment ratio, elementary level

Table 16. Elementary level: Gross enrolment ratio 1991/92-2007/08

Year	Total Population 7-11			Enrolment in elementary level			Gross enrolment ratio		
	T	M	F	T	M	F	T	M	F
1991/92	375,234	198,552	176,682	150,982	81,746	69,236	40.2	41.2	39.2
1992/93	388,581	206,052	182,529	184,656	102,235	82,421	47.5	49.6	45.2
1993/94	401,679	213,000	188,679	208,199	115,663	92,536	51.8	54.3	49.0
1994/95	414,606	219,502	195,104	224,287	124,544	99,743	54.1	56.7	51.1
1995/96	427,429	225,658	201,771	241,725	133,471	108,254	56.5	59.2	53.7
1996/97	440,171	231,537	208,634	240,737	132,250	108,487	54.7	57.1	52.0
1997/98	451,076	236,293	214,783	247,499	135,569	111,930	54.9	57.4	52.1
1998/99	478,441	249,970	228,471	261,963	143,578	118,385	54.7	57.4	51.8
1999/00	470,652	239,841	230,811	295,941	162,896	133,045	62.9	67.9	57.6
2000/01	486,639	248,232	238,407	298,691	164,523	134,168	61.4	66.3	56.3
2001/02	504,246	257,793	246,453	330,278	184,060	146,218	65.5	71.4	59.3
2002/03	511,350	260,568	250,782	359,423	199,860	159,563	70.3	76.7	63.6
2003/04	522,975	268,340	254,635	374,997	209,043	165,954	71.7	77.9	65.8
2004/05	526,266	271,547	254,719	377,512	210,061	167,451	71.7	77.4	65.7
2005/06	518,357	268,669	249,688	364,263	202,388	161,875	70.3	75.3	64.8
2006/07	497,762	258,858	238,904	331,855	182,100	149,755	66.7	70.3	62.7
2007/08	468,165	243,937	224,228	314,034	173,242	140,792	67.1	71.0	62.8

N.B the increasing and decreasing trend of the GER needs special attention.

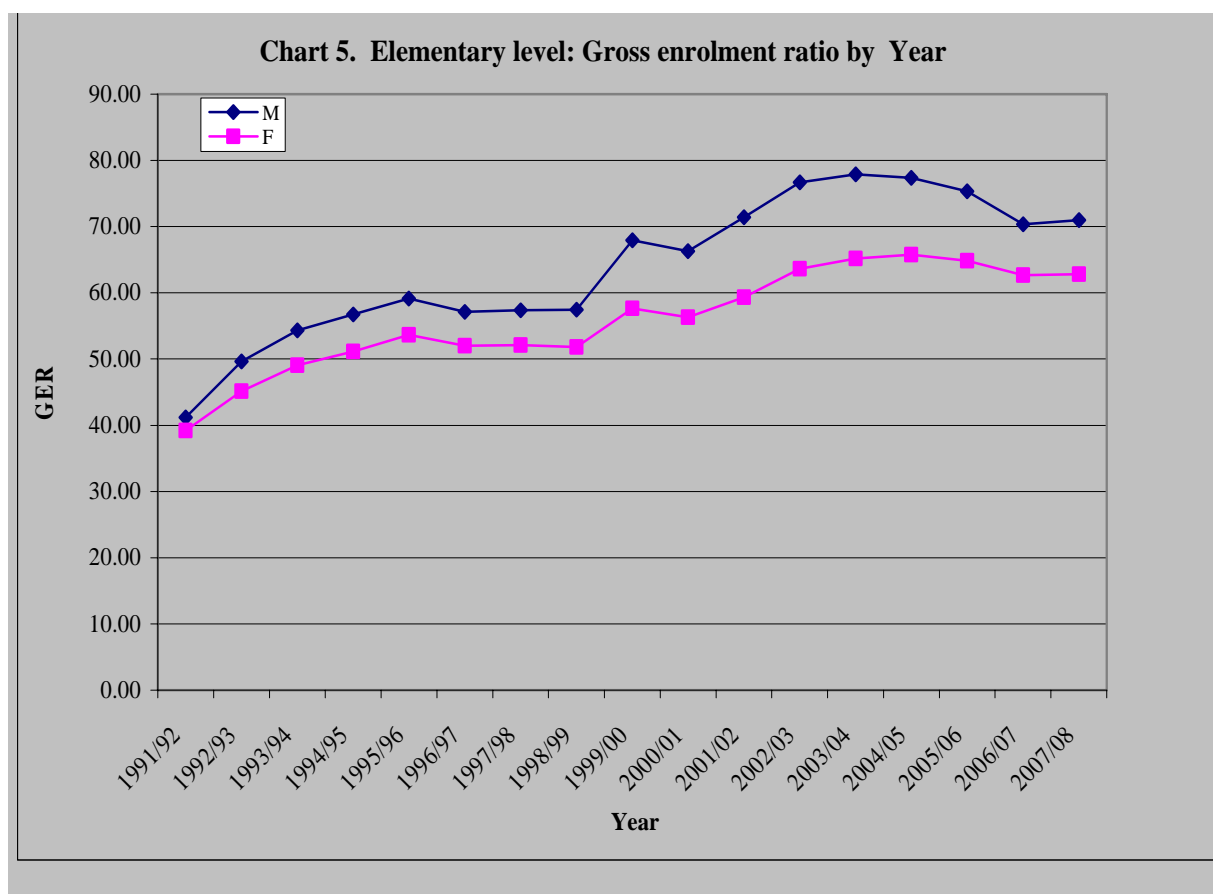

9. Net enrolment ratio

Table 17. Elementary level: Net enrolment and net enrolment ratio: 1991/92-2007/08

Year	Population age 7-11.			Net enrolment			Net enrolment ratio %		
	T	M	F	T	M	F	T	M	F
1991/92	375,234	198,552	176,682	93,087	48,397	44,690	24.8	24.4	25.3
1992/93	388,581	206,052	182,529	109,111	57,126	51,985	28.1	27.7	28.5
1993/94	401,679	213,000	188,679	113,612	59,645	53,967	28.3	28.0	28.6
1994/95	414,606	219,502	195,104	122,084	64,098	57,986	29.5	29.2	29.7
1995/96	427,429	225,658	201,771	133,496	69,958	63,538	31.3	31.0	31.5
1996/97	440,171	231,537	208,634	136,943	72,073	64,870	31.1	31.1	31.1
1997/98	451,076	236,293	214,783	150,751	80,212	70,539	33.4	34.0	32.8
1998/99	478,441	249,970	228,471	166,879	89,556	77,323	34.9	35.8	33.8
1999/00	470,652	239,841	230,811	194,963	104,743	90,215	41.4	43.7	39.1
2000/01	486,639	248,232	238,407	205,831	111,022	94,809	42.3	44.7	39.8
2001/02	504,246	257,793	246,453	232,030	125,941	106,089	46.0	48.9	43.1
2002/03	511,350	260,568	250,782	256,360	139,072	117,288	50.1	53.4	46.8
2003/04	522,975	268,340	254,635	269,326	146,379	122,947	51.1	54.4	48.3
2004/05	526,266	271,547	254,719	276,815	149,916	126,899	52.6	55.2	49.8
2005/06	518,357	268,669	249,688	272,401	146,588	125,813	52.6	54.6	50.4
2006/07	497,762	258,858	238,904	248,782	133,238	115,544	50.0	51.5	48.4
2007/08	468,165	243,937	224,228	233,590	125,816	107,774	49.9	51.6	48.1

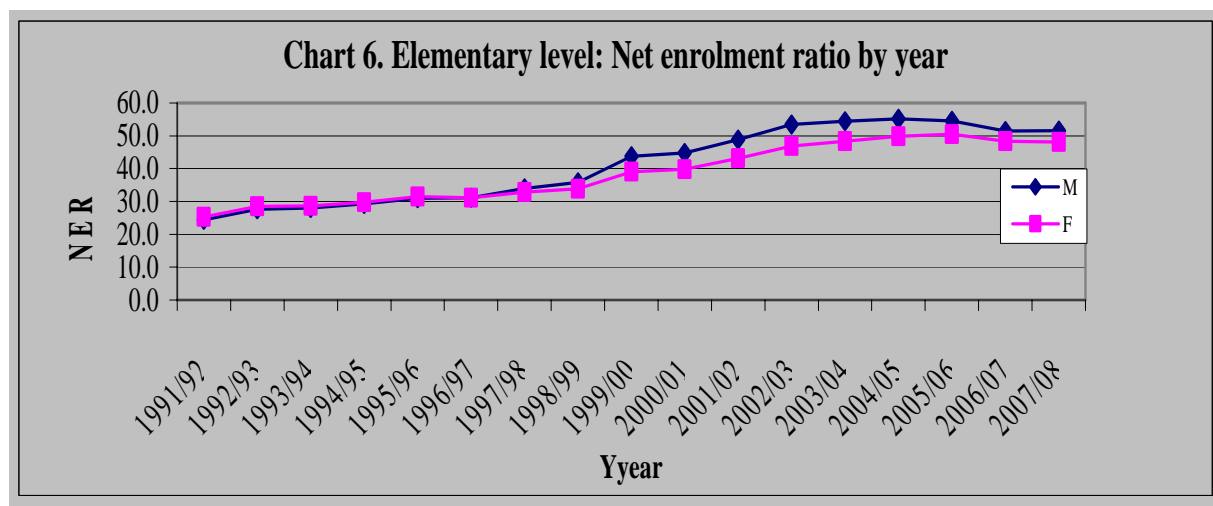

N.B Starting from 2004/05 the NER is decreasing hence, a study needs to be carried out to identify the cause.

10. Elementary level: percentage of repeaters

Table 18. Elementary level: Enrolment, repeaters and percentage of repeaters by gender 1991/92-2007/08

Year	Enrolment			Repeaters			Percentage of repeaters		
	T	M	F	T	M	F	T	M	F
1991/92	150,982	81,746	69,236	N. A.	N.A.	N. A.	N.A.	N. A.	N.A.
1992/93	184,656	102,235	82,421	47,139	23,289	23,850	25.5	22.8	28.9
1993/94	208,199	115,663	92,536	41,694	20,632	21,062	20.0	17.8	22.8
1994/95	224,287	124,544	99,743	42,426	21,177	21,249	18.9	17.0	21.3
1995/96	241,725	133,471	108,254	49,172	24,470	24,702	20.3	18.3	22.8
1996/97	240,737	132,250	108,487	49,246	25,006	24,240	20.5	18.9	22.3
1997/98	247,499	135,569	111,930	56,157	28,613	27,544	22.7	21.1	24.6
1998/99	261,963	143,578	118,385	50,820	26,168	24,652	19.4	18.2	20.8
1999/00	295,941	162,896	133,045	57,366	30,798	26,568	19.4	18.9	20.0
2000/01	298,691	164,523	134,168	41,387	22,499	18,888	13.9	13.7	14.1
2001/02	330,278	184,060	146,218	47,249	21,005	26,244	14.3	11.4	17.9
2002/03	359,399	199,842	159,557	73,114	39,485	33,629	20.3	19.8	21.1
2003/04	374,997	209,043	165,954	80,020	43,208	36,812	21.3	20.7	22.2
2004/05	377,512	210,061	167,451	48,629	27,373	21,256	12.9	13.0	12.7
2005/06	364,263	202,388	161,875	49,923	28,068	21,858	13.7	13.9	13.5
2006/07	331,855	182,100	149,755	48,443	27,213	21,230	14.6	14.9	14.2
2007/08	314,034	173,242	140,792	48,393	27,773	20,620	15.4	16.0	14.6

The above table indicates total number of repeaters repeating the same grade in current academic year.

11. Disparities among zobas

Table 19. Elementary level: Gross enrolment and deviation from the national ratio by zoba, 2007/08

Zoba	Population age 7-11	Gross enrolment	Gross enrolment ratio	Deviation from national ratio
Anseba	66,536	47,684	71.7	4.6
Debub	118,145	111,401	94.3	27.2
Deb-Keih-B	10,012	4,072	40.7	-26.4
Gash Barka	109,912	61,605	56.0	-11.1
Maekel	84,743	64,434	76.0	8.9
Sem-Keih-B	78,817	24,838	31.5	-35.1
Total	468,165	314,034	67.1	0.0

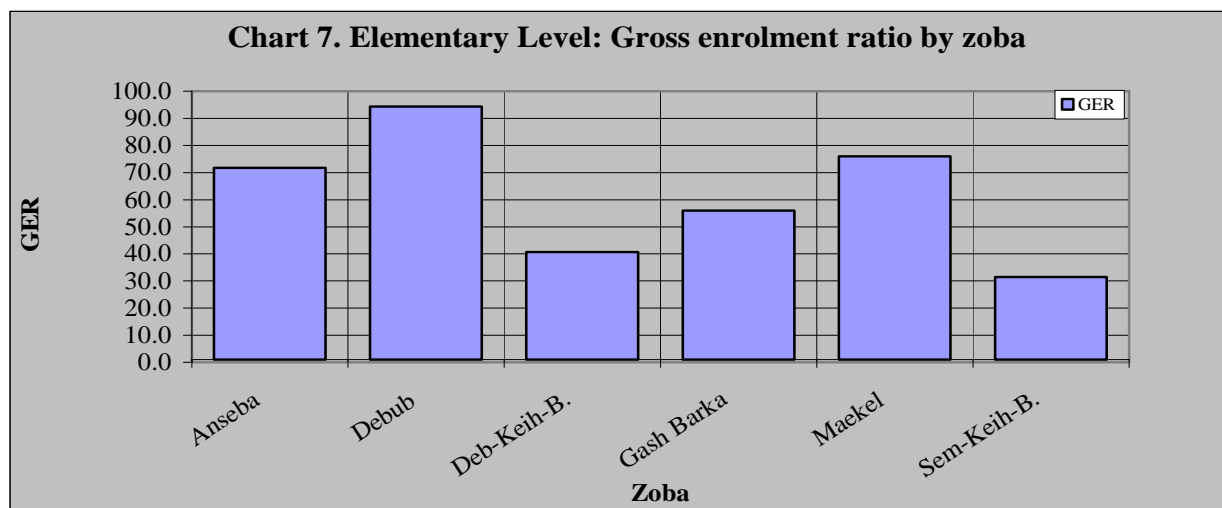

Table 20. Elementary level: Net enrolment ratio and deviation from the national ratio by zoba, 2007/08

Zoba	Population age 7-11	Net enrolment	Net enrolment ratio	Deviation from national ratio
Anseba	66,536	36,155	54.3	4.4
Debub	118,145	81,081	68.6	18.7
Deb-Keih-B	10,012	2,651	26.5	-23.4
Gash-Barka	109,912	45,842	41.7	-8.2
Maekel	84,743	49,222	58.1	8.2
Sem-Keih-B	78,817	18,639	23.6	-26.3
Total	468,165	233,590	49.9	0.0

VI. Middle level

1. Duration

The duration of Middle level is three years (Grades 6, 7 and 8). It is the second level of the compulsory basic education. English is the language of instruction in this level. School age for this level is 12-14.

2. Enrolment

Enrolment in this level for the academic year 2007/08 was 144,031. Female enrolment constitute 60,265 (41.8%) of the total number. Non-government enrolment in this level is 10,460 (7.3%)

Table 21. Middle level: Enrolment by grade, gender and zoba, 2007/08

Zoba	Grades 6-8			Grade 6			Grade 7			Grade 8		
	T	M	F	T	M	F	T	M	F	T	M	F
Anseba	17,815	10,522	7,293	7,617	4,411	3,206	5,476	3,291	2,185	4,722	2,820	1,902
Debub	53,604	31,583	22,021	21,888	12,734	9,154	17,998	10,708	7,290	13,718	8,141	5,577
Deb-Keih-B	1,932	1,495	437	676	531	145	682	516	166	574	448	126
Gash-Barka	18,430	11,924	6,506	8,278	5,197	3,081	5,723	3,769	1,954	4,429	2,958	1,471
Maekel	43,236	22,128	21,108	14,661	7,844	6,817	13,645	7,072	6,573	14,930	7,212	7,718
Sem-Keih-B	9,014	6,114	2,900	3,932	2,615	1,317	2,721	1,884	837	2,361	1,615	746
Totals	144,031	83,766	60,265	57,052	33,332	23,720	46,245	27,240	19,005	40,734	23,194	17,540

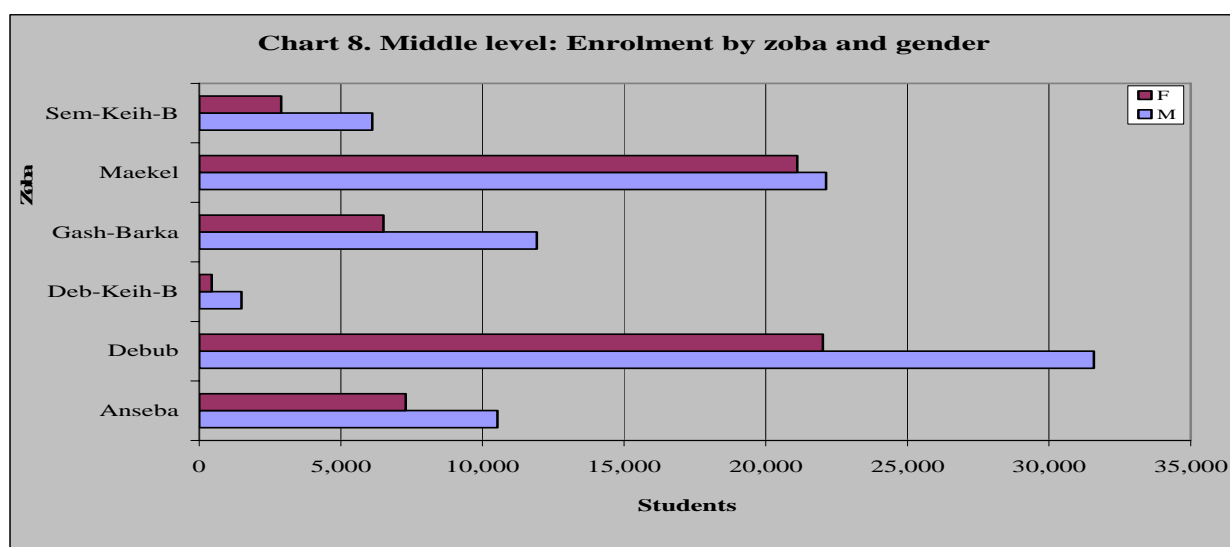

3. Gross enrolment ratio

Table 22. Middle level: Gross enrolment ratio 1991/92-2007/08

Year	Population 12-13			Enrolment			Gross enrolment ratio		
	T	M	F	T	M	F	T	M	F
1991/92	136,712	72,904	63,808	27,917	14,414	13,503	20.2	19.8	21.2
1992/93	141,576	75,657	65,919	28,431	15,052	13,379	20.1	19.9	20.3
1993/94	146,349	78,209	68,140	32,781	18,129	14,652	22.4	23.2	21.5
1994/95	151,058	80,597	70,461	34,995	19,310	15,685	23.8	24.0	22.3
1995/96	155,725	82,856	72,869	39,751	21,648	18,103	25.5	26.1	24.8
1996/97	160,363	85,015	75,348	47,460	26,739	20,721	29.6	31.5	27.5
1997/98	164,331	86,762	77,569	57,152	32,998	24,154	34.8	38.0	31.1
1998/99	174,295	91,783	82,512	67,021	37,731	29,290	38.5	41.1	35.5
1999/00	164,059	81,820	82,239	74,317	41,033	33,284	45.3	50.2	40.5
2000/01	169,628	84,683	84,945	76,564	41,457	35,107	45.1	49.0	41.3
2001/02	175,758	87,947	87,811	80,882	46,215	34,667	46.0	52.6	39.5
2002/03	178,245	88,891	89,354	87,019	50,138	36,881	48.8	56.4	41.3
	Population 12-14			Enrolment			Gross enrolment ratio		
2003/04	274,014	136,804	137,210	122,966	73,742	49,224	44.9	53.9	35.9
2004/05	287,129	143,975	143,154	139,029	85,033	53,996	48.4	59.1	37.7
2005/06	299,324	151,298	148,026	148,082	90,634	57,448	49.5	59.9	38.8
2006/07	331,538	178,807	152,731	141,081	81,739	59,342	42.3	45.7	38.9
2007/08	322,062	165,323	156,739	144,031	83,766	60,265	44.7	50.7	38.4

In the academic year 2003/04 enrolment in middle school is seen to increase tremendously; this is due to the rearrangement of grades. (Grade 8 was made to be part of the middle level)

Chart 9 Middle level: Enrolment by year and gender

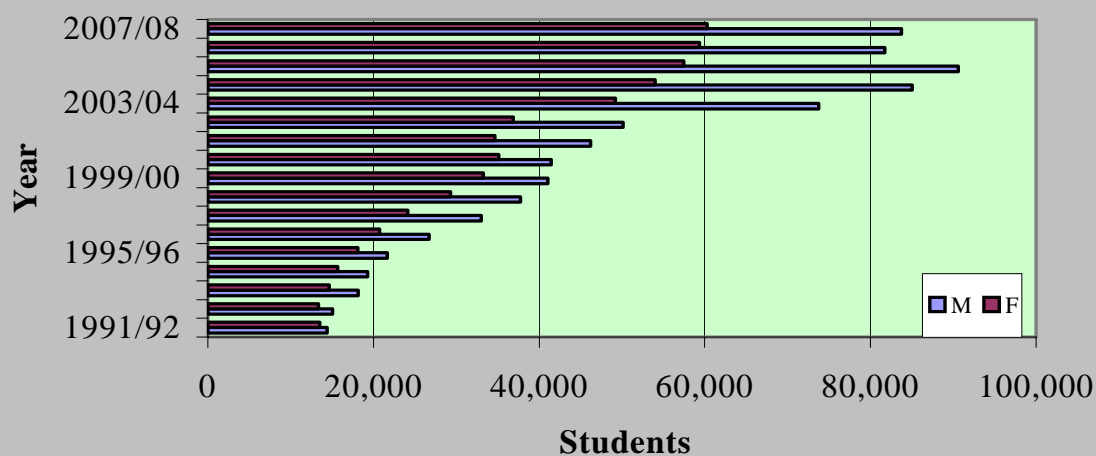

Table 23. Middle level: Gross enrolment ratio and deviation from the national ratio by zoba, 2007/08

Zoba	Population age 12-14	Gross enrolment	Gross enrolment ratio	Deviation from national ratio
Anseba	45,771	17,815	38.9	-5.8
Debub	81,275	53,604	66.0	21.3
Deb-Keih-B	6,888	1,932	28.0	-16.7
Gash Barka	75,611	18,430	24.3	-20.4
Maekel	58,297	43,236	74.2	29.5
Sem-Keih-B	54,220	9,014	16.6	-28.1
Total	322,062	144,031	44.7	0.0

4. Net enrolment ratio**Table 24. Middle level: Net enrolment ratio 1991/92-2007/08**

Year	Population 12-13			Net enrolment			Net enrolment ratio		
	T	M	F	T	M	F	T	M	F
1991/92	136,712	72,904	63,808	9,727	5,111	4,616	7.1	7.1	7.2
1992/93	141,576	75,657	65,919	7,941	4,275	3,666	5.6	5.7	5.6
1993/94	146,349	78,209	68,140	8,594	4,604	3,990	5.9	5.9	5.7
1994/95	151,058	80,597	70,461	9,074	4,763	4,311	6.0	5.9	6.1
1995/96	155,725	82,856	72,869	9,988	5,299	4,689	6.4	6.4	6.4
1996/97	160,363	85,015	75,348	12,604	6,925	5,679	7.9	8.2	7.5
1997/98	164,331	86,762	77,569	14,751	8,062	6,689	9.0	9.3	8.6
1998/99	174,295	91,783	82,512	15,878	8,400	7,478	9.1	9.2	9.1
1999/00	164,059	81,820	82,239	18,201	9,552	8,649	11.1	11.7	10.5
2000/01	169,628	84,683	84,945	20,409	10,639	9,770	12.0	12.6	11.5
2001/02	175,758	87,947	87,811	22,348	11,718	10,630	12.7	13.3	12.1
2002/03	178,245	88,891	89,354	24,584	13,057	11,527	13.8	14.7	12.9
	Population 12-14			Enrolment			Gross enrolment ratio		
2003/04	274,014	136,804	137,210	51,795	28,632	23,163	18.9	20.9	16.9
2004/05	287,129	143,975	143,154	60,323	33,879	26,444	21.0	23.5	18.5
2005/06	299,324	151,298	148,026	66,708	37,334	29,374	22.3	24.7	19.8
2006/07	311,538	158,807	152,731	72,729	40,276	32,453	23.3	25.4	21.3
2007/08	322,062	165,323	156,739	80,570	44,496	36,074	25.0	26.9	23.0

Table 25. Middle level: Net enrolment ratio by zoba, 2007/08

Zoba	Population age 12-14	Net enrolment	Net enrolment ratio	Deviation from national ratio
Anseba	45,771	10,216	22.3	-2.7
Debub	81,275	29,494	36.3	11.3
Deb-Keih-B	6,888	679	9.9	-15.1
Gash-Barka	75,611	9,791	12.9	-12.1
Maekel	58,297	25,343	43.5	18.5
Sem-Keih-B	54,220	5,047	9.3	-15.7
Total	322,062	80,570	25.0	0.0

5. Percentage of repeaters

Table 26. Middle level: Total number and percentage of repeaters 1991/92-2007/08

Year	Enrolment			Repeaters			Percentage of Repeaters		
	T	M	F	T	M	F	T	M	F
1991/92	27,917	14,414	13,503	N.A	N.A	N.A	N.A	N.A	N.A
1992/93	28,431	15,052	13,379	12,256	4,116	8,140	43.1	27.3	60.8
1993/94	32,781	18,129	14,652	5,544	2,120	3,424	16.9	11.7	23.4
1994/95	34,995	19,310	15,685	4,736	1,781	2,955	13.5	9.2	18.8
1995/96	39,751	21,648	18,103	5,329	1,918	3,411	13.4	8.9	18.8
1996/97	47,460	26,739	20,721	6,193	2,385	3,808	13.1	8.9	18.4
1997/98	57,152	32,998	24,154	8,707	3,401	5,306	15.2	10.3	22.0
1998/99	67,021	37,731	29,290	12,119	5,042	7,077	18.1	13.4	24.2
1999/00	74,317	41,033	33,284	15,632	7,053	8,579	21.0	17.2	25.8
2000/01	76,564	41,457	35,107	16,870	8,025	8,845	22.0	19.4	25.2
2001/02	80,882	46,215	34,667	17,419	9,029	8,390	21.5	19.5	24.2
2002/03	87,019	50,138	36,881	23,126	12,163	10,963	26.6	24.3	29.7
2003/04	122,966	73,742	49,224	21,352	12,648	8,704	17.4	17.2	17.7
2004/05	139,029	85,033	53,996	15,735	10,451	5,286	11.3	12.3	9.8
2005/06	148,082	90,634	57,448	25,283	16,719	8,564	17.1	18.5	14.9
2006/07	141,081	81,342	59,342	21,919	12,723	9,196	15.4	15.6	15.5
2007/08	144,031	83,766	60,265	20,151	11,852	8,299	14.0	14.1	13.8

The above table indicates total number of repeaters repeating the same grade in current academic year.

The percentage of repeaters has been declining between 1992/93 and 1996/97 but has been increasing starting from 1996/97 up to 2002/03 with the exception of 2001/02. From 2002/03 up to 2007/08 a decreasing trend is seen except for the academic year 2005/06.

VII. Secondary level

1. Duration

The duration of Secondary level is four years (Grades 9-12).

2. Enrolment

Enrolment for the academic year 2007/08 was 83,411. Female enrolment constitutes 34,088 (40.9%). Approximately 2.8% of the students in the Secondary level were attending non-government schools.

Table 27. Secondary level: Enrolment by gender and zoba, 2007/08

Zoba	Grade 9-12			Grade 9		Grade 10		Grade 11		Grade 12	
	T	M	F	M	F	M	F	M	F	M	F
Anseba	8,049	5,093	2,956	2,516	1,480	1,448	847	1,129	629	0	0
Debub	25,398	15,955	9,443	7,479	4,611	5,237	3,036	3,239	1,796	0	0
Beb-Keih-B	1,150	902	248	402	81	278	96	222	71	0	0
Gash-Barka	6,771	4,621	2,150	2,394	1,066	1,384	672	843	412	0	0
Mackle	27,842	14,090	13,752	6,073	6,059	4,399	4,346	3,617	3,343	1	4
Sawa	10,119	5,720	4,399	0	0	0	0	0	0	5,720	4,399
Sem-Keih-B	4,082	2,942	1,140	1,602	606	744	321	596	213	0	0
Total	83,411	49,323	34,088	20,466	13,903	13,490	9,318	9,646	6,464	5,721	4,403

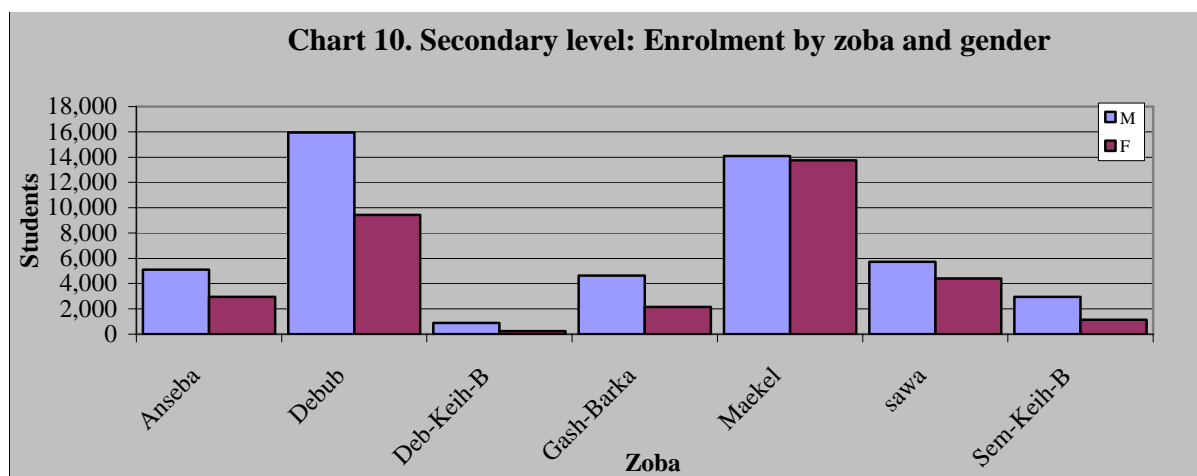

3. Gross enrolment ratio

Table 28. Secondary level: Gross enrolment ratio 1991/92-2007/08

Year	Population of age 14-17			Enrolments			Gross enrolment ratio		
	T	M	F	T	M	F	T	M	F
1991/92	210,515	110,133	100,382	27,627	14,281	13,346	13.1	13.0	13.3
1992/93	217,998	114,293	103,705	31,531	17,141	14,390	14.5	15.0	13.9
1993/94	225,344	118,144	107,200	32,756	19,432	13,324	14.5	16.5	12.4
1994/95	232,603	121,753	110,850	36,728	22,097	14,631	15.8	18.2	13.2
1995/96	239,805	125,167	114,638	39,188	23,713	15,475	16.3	19.0	13.5
1996/97	246,964	128,427	118,537	40,594	24,262	16,332	16.4	18.9	13.8
1997/98	253,097	131,066	122,031	41,615	25,198	16,417	16.4	19.2	13.5
1998/99	268,460	138,652	129,808	47,533	29,777	17,756	17.7	21.5	13.7
1999/00	272,871	139,459	133,412	59,626	37,533	22,093	21.9	26.9	16.6
2000/01	282,140	144,338	137,802	63,951	40,355	23,596	22.7	28.0	17.1
2001/02	292,355	149,903	142,452	70,183	45,129	25,054	24.0	30.1	17.6
2002/03	296,466	151,511	144,955	72,818	46,633	26,185	24.6	30.8	18.1
	Population of age 15-18			Enrolment			Gross enrolment ratio		
2003/04	296,218	151,315	144,903	69,401	46,449	22,952	23.4	30.7	15.8
2004/05	316,462	160,167	156,295	76,051	50,010	26,041	24.0	31.2	16.7
2005/06	336,080	168,631	167,449	77,644	50,351	27,293	23.1	29.9	16.3
2006/07	355,028	177,431	177,597	75,800	45,471	30,329	21.4	25.6	17.1
2007/08	373,008	186,640	186,368	83,411	49,323	34,088	22.4	26.4	18.3

Table 29. Secondary level: Gross enrolment ratio by zoba, 2007/08

Zoba	Population age 15-18	Gross enrolment	Gross enrolment ratio	Deviation from national ratio
Anseba	53,012	8,049	15.2	-7.2
Debub	94,132	25,398	27.0	4.6
Deb-Keih-B	7,977	1,150	14.4	-8.0
Gash Barka	87,572	6,771	7.7	-14.7
Maekel	67,519	27,842	41.2	18.8
Sawa	0	10,119	0	0.0
Sem-Keih-B	62,797	4,082	6.5	-15.9
Total	373,009	83,411	22.4	0.0

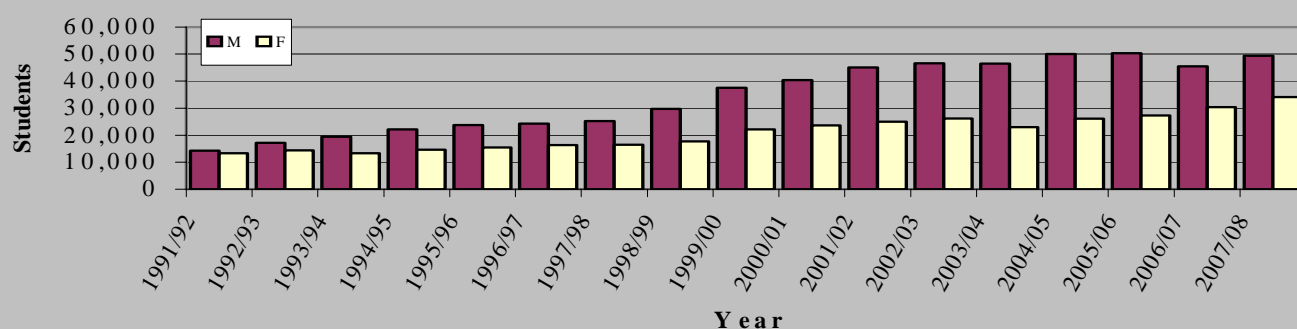
Chart 11. Secondary level: Enrolment by year and gender

4. Net enrolment ratio

Table 30. Secondary level: Net enrolment ratio 1991/92-2007/08

Year	Population of age 14-17			Net enrolment			Net enrolment ratio		
	T	M	F	T	M	F	T	M	F
1991/92	210,515	110,133	100,382	19,131	9,999	9,132	9.1	9.1	9.1
1992/93	217,998	114,293	103,705	19,880	9,951	9,929	9.1	8.7	9.6
1993/94	225,344	118,144	107,200	19,097	9,932	9,165	8.5	8.4	8.6
1994/95	232,603	121,753	110,850	22,108	11,584	10,524	9.5	9.5	9.5
1995/96	239,805	125,167	114,638	23,780	12,788	10,992	9.9	10.2	9.6
1996/97	246,964	128,427	118,537	25,911	13,822	12,089	10.5	10.8	10.2
1997/98	253,097	131,066	122,031	27,357	14,817	12,540	10.8	11.3	10.3
1998/99	268,460	138,652	129,808	30,995	17,755	13,240	11.6	12.8	10.2
1999/00	272,871	139,459	133,412	39,197	22,800	16,397	14.4	16.4	12.3
2000/01	282,140	144,338	137,802	38,271	22,482	15,789	13.6	15.6	11.5
2001/02	292,355	149,903	142,452	41,748	24,906	16,842	14.3	16.6	11.8
2002/03	296,466	151,511	144,955	48,269	28,612	19,657	16.3	18.9	13.6
	Population 15-18			Net enrolment			Net enrolment ratio		
2003/04	296,218	151,315	144,903	41,757	25,549	16,208	14.1	16.9	11.2
2004/05	316,462	160,167	156,295	41,523	24,702	16,821	13.1	15.4	10.8
2005/06	336,080	168,631	167,449	44,637	25,942	18,695	13.3	15.4	11.2
2006/07	355,028	177,431	177,597	50,266	29,245	21,021	14.2	16.5	11.8
2007/08	373,008	186,640	186,368	56,261	32,261	23,310	15.1	17.2	12.5

Table 31. Secondary Level: Net Enrolment Ratio by zoba, 2007/08

Zoba	Population age 15-18	Net enrolment	Net enrolment ratio	Deviation from national ratio
Anseba	53,012	6,267	11.8	-3.3
Debub	94,132	17,764	18.9	3.8
Deb-Keih-B	7,977	745	9.3	-5.8
Gash-Barka	87,572	5,171	5.9	-9.2
Maekel	67,519	20,400	30.2	15.1
Sawa	0	2,809	0.0	0.0
Sem-Keih-B	62,797	3,105	5.0	-10.1
Total	373,009	56,261	15.1	0.0

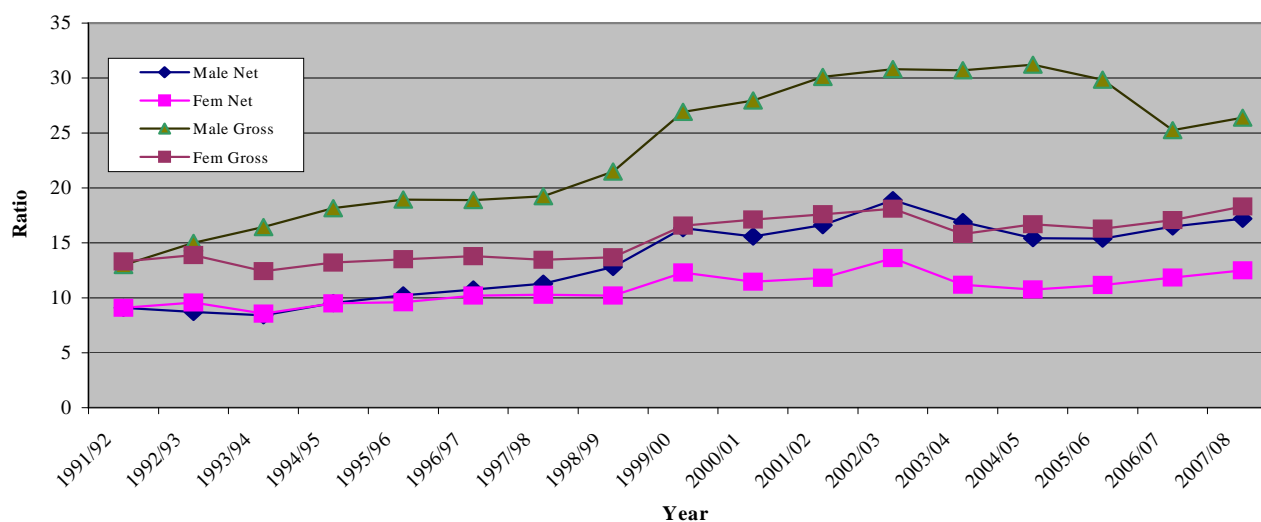
Chart 12. Secondary level: GER and NER by gender and year

5. Percentage of repeaters

Table 32. Secondary level: Total number and percentage of repeaters by gender, 1991/92-2007/08

Year	Enrolment			Repeaters			Percentage		
	T	M	F	T	M	F	T	M	F
1991/92	27,627	14,281	13,346	11,072	4,241	6,831	40.1	29.7	51.2
1992/93	31,531	17,141	14,390	11,426	4,341	7,085	36.2	25.3	49.2
1993/94	32,756	19,432	13,324	7,504	3,212	4,292	22.9	16.5	32.2
1994/95	36,728	22,097	14,631	6,182	2,704	3,478	16.8	12.2	23.8
1995/96	39,188	23,713	15,475	7,296	3,113	4,183	18.6	13.1	27.0
1996/97	40,594	24,262	16,332	7,135	3,272	3,863	17.6	13.5	23.7
1997/98	41,615	25,198	16,417	7,648	3,305	4,343	18.4	13.1	26.4
1998/99	47,533	29,777	17,756	5,941	2,813	3,128	12.4	9.4	17.6
1999/00	57,334	36,504	20,830	7,640	3,999	3,641	13.3	11.0	17.5
2000/01	63,951	40,355	23,596	11,627	6,747	4,880	18.2	16.7	20.7
2001/02	70,183	45,129	25,054	13,321	7,902	5,419	19.0	17.5	21.6
2002/03	72,818	46,633	26,185	13,922	8,363	5,559	19.1	17.9	21.2
2003/04	69,401	46,449	22,952	11,437	7,418	4,019	16.8	16.0	17.5
2004/05	76,051	50,010	26,041	4,066	3,258	808	5.3	6.5	3.1
2005/06	77,644	50,351	27,293	3,066	2,765	301	4.0	5.5	1.1
2006/07	75,800	45,471	30,329	6,190	4,465	1,725	8.2	9.8	5.7
2007/08	83,411	49,323	34,088	4,998	3,318	1,680	6.0	6.7	4.9

The above table indicates total number of repeaters repeating the same grade in current academic year.

VIII. Internal efficiency

1. Length of school year.

The duration of the school year in the academic year 2007/08 was 180 days in the highlands and 181 days in the lowlands. The number of periods per week in grades 1, 2, and 3 were 26, 27, and 28 respectively and in grades 4 and 5 were 30.

In the academic year 2007/08, schooling in the highlands began on August 27 and ended on June 30. In the lowlands it began on September 3 and ended on June 16. Schools in the lowlands, teach 6 days a week while schools in the highlands, teach 5 days a week.

The duration of the school year in the academic year 2007/08 is shown in table 32

Table 33. Elementary level: Duration of school year, 2007/08

Grade	Periods per week	Length of a period (minute)	Total number of periods per year	Contact hrs.
1	29	40	832	555
2	27	40	864	576
3	28	40	898	599
4	30	40	960	640
5	30	40	960	640

Duration of school year in both locations is the same.

2. All grades: Flow rates

Table 34. All grades: Flow rates by gender and grade, 2007/08

Grade	Dropout			Promotion			Repetition		
	M	F	T	M	F	T	M	F	T
1	8.9	7.4	8.2	76.4	78.5	77.3	14.7	14.1	14.5
2	5.4	4.4	4.9	74.5	77.6	75.9	20.1	18.0	19.2
3	5.2	4.3	4.8	79.0	81.4	80.1	15.8	14.2	15.1
4	5.5	4.2	4.9	79.1	82.3	80.5	15.4	13.4	14.5
5	5.0	4.0	4.6	84.1	85.7	84.8	10.9	10.4	10.7
1-5	6.0	4.8	5.5	78.6	81.1	79.7	15.4	14.1	14.8
6	7.9	4.9	6.6	70.9	76.4	73.2	21.2	18.7	20.2
7	6.3	4.8	5.7	80.8	84.5	82.3	12.9	10.6	12.0
8	5.6	6.2	5.9	82.4	84.8	83.4	12.0	9.0	10.7
6-8	6.7	5.3	6.1	77.3	81.4	79.0	16.0	13.3	14.9
9	8.4	7.4	8.0	67.7	77.6	71.7	23.9	15.0	20.3
10	8.5	10.8	9.4	74.9	77.0	75.8	16.6	12.3	14.8
11	6.8	11.3	8.6	91.5	87.1	89.8	1.7	1.6	1.6
12	N.A	N.A	N.A	N.A	N.A	N.A	N.A	N.A	N.A
9-12	8.1	9.3	8.6	75.2	79.5	76.9	16.7	11.2	14.5

3. Elementary level: Flow rates

Table 35. Elementary level: Flow rates by age, grade and gender, 2007/08

Age	Grade 1									Grade 2								
	Dropout			Promotion			Repetition			Dropout			Promotion			Repetition		
	M	F	T	M	F	T	M	F	T	M	F	T	M	F	T	M	F	T
5	8.3	12.6	10.2	74.4	67.2	71.3	17.3	20.2	18.5	0.0	0.0	0.0	0.0	0.0	0.0	100.0	0.0	100.0
6	7.7	6.0	6.9	73.4	78.1	75.6	18.8	15.9	17.5	2.1	0.0	1.3	88.2	88.1	88.2	9.6	11.9	10.5
7	9.0	7.6	8.4	76.1	77.5	76.7	14.9	14.9	14.9	3.3	2.4	2.9	78.5	83.8	81.1	18.2	13.8	16.0
8	9.8	8.2	9.1	79.6	80.6	80.0	10.6	11.3	10.9	4.9	3.9	4.4	73.2	76.6	74.7	21.9	19.6	20.8
9	10.1	10.5	10.2	82.1	80.4	81.4	7.8	9.1	8.3	5.9	5.2	5.6	74.1	75.8	74.8	20.0	19.0	19.6
10	12.5	11.7	12.2	79.0	80.2	79.4	8.5	8.1	8.3	8.0	6.6	7.4	73.1	74.0	73.4	19.0	19.5	19.2
11	10.3	9.3	10.0	83.6	85.2	84.1	6.0	5.6	5.9	8.1	10.5	9.0	71.3	66.7	69.5	20.6	22.7	21.4
12	15.4	18.8	16.7	75.0	75.0	75.0	9.6	6.3	8.3	11.6	7.7	10.3	71.0	68.3	70.1	17.3	24.0	19.6
13	0.0	11.1	7.1	80.0	77.8	78.6	20.0	11.1	14.3	9.2	20.8	12.1	73.2	56.3	68.9	17.6	22.9	18.9
14	12.5	0.0	11.1	75.0	100.0	77.8	12.5	0.0	11.1	22.0	12.5	20.7	68.0	50.0	65.5	10.0	37.5	13.8
15	0.0	0.0	0.0	66.7	100.0	75.0	33.3	0.0	25.0	8.0	0.0	8.0	84.0	0.0	84.0	8.0	0.0	8.0
16	0.0	0.0	0.0	0.0	0.0	0.0	100.0	0.0	100.0	25.0	50.0	33.3	50.0	50.0	50.0	25.0	0.0	16.7
17	0.0	0.0	0.0	0.0	0.0	0.0	0.0	0.0	0.0	0.0	0.0	0.0	100.0	0.0	100.0	0.0	0.0	0.0
>18	0.0	0.0	0.0	0.0	0.	0.0	100.0	0.0	100.0	0.0	0.0	0.0	0.0	0.0	0.0	0.0	0.0	0.0
Total	8.9	7.4	8.2	76.4	78.5	77.3	14.7	14.1	14.5	5.4	4.4	4.9	74.5	77.6	75.9	20.1	18.0	19.2

Age	Grade 3									Grade 4								
	Dropout			Promotion			Repetition			Dropout			Promotion			Repetition		
	M	F	T	M	F	T	M	F	T	M	F	T	M	F	T	M	F	T
5	0.0	0.0	0.0	0.0	0.0	0.0	0.0	0.0	0.0	0.0	0.0	0.0	0.0	0.0	0.0	0.0	0.0	0.0
6	40.0	0.0	28.6	40.0	50.0	42.9	20.0	50.0	28.6	0.0	0.0	0.0	0.0	0.0	0.0	0.0	0.0	0.0
7	6.1	0.0	3.6	79.6	84.6	81.7	14.3	15.4	14.7	12.5	0.0	10.0	75.0	100.0	80.0	12.5	0.0	10.0
8	2.7	2.1	2.4	85.5	87.3	86.4	11.9	10.6	11.2	6.3	3.5	5.0	82.8	89.4	85.8	10.9	7.1	9.2
9	3.7	3.5	3.6	79.8	82.5	81.1	16.5	14.0	15.3	2.8	2.0	2.4	85.4	89.4	87.4	11.8	8.6	10.2
10	5.1	4.8	4.9	78.5	79.8	79.1	16.4	15.4	15.9	3.7	3.2	3.5	81.0	84.0	82.5	15.3	12.7	14.1
11	7.4	6.5	7.0	76.3	76.7	76.5	16.3	16.8	16.5	5.0	4.0	4.6	79.2	81.5	80.2	15.8	14.5	15.2
12	8.1	7.9	8.0	74.4	77.7	75.6	17.5	14.4	16.3	6.7	5.6	6.3	76.7	78.7	77.5	16.6	15.7	16.3
13	12.2	11.9	12.1	70.4	71.7	70.8	17.4	16.4	17.1	10.3	8.0	9.5	73.1	74.8	73.7	16.6	17.2	16.8
14	15.0	7.4	12.8	69.1	79.3	72.0	15.9	13.3	15.2	10.9	13.5	11.8	70.3	68.8	69.8	18.7	17.7	18.4
15	18.9	4.0	16.2	71.2	64.0	69.9	9.9	32.0	14.0	14.8	13.2	14.4	70.2	70.1	70.2	15.0	16.7	15.4
16	39.1	0.0	37.5	47.8	100.0	50.0	13.0	0.0	12.5	14.9	15.2	15.0	63.2	72.7	64.7	21.8	12.1	20.3
17	0.0	0.0	0.0	56.3	0.0	56.3	43.8	0.0	43.8	13.6	0.0	11.8	70.5	85.7	72.5	15.9	14.3	15.7
>18	20.0	0.0	16.7	40.0	0.0	33.3	40.0	100.0	50.0	28.6	0.0	20.0	42.9	66.7	50.0	28.6	33.3	30.0
Total	5.2	4.3	4.8	78.9	81.4	80.1	15.8	14.2	15.1	5.5	4.2	4.9	79.1	82.3	80.5	15.4	13.4	14.5

Age	Grade 5									Grade 1-5								
	Dropout			Promotion			Repetition			Dropout			Promotion			Repetition		
	M	F	T	M	F	T	M	F	T	M	F	T	M	F	T	M	F	T
5	0.0	0.0	0.0	0.0	0.0	0.0	0.0	0.0	0.0	8.3	12.6	10.1	73.9	67.2	71.0	17.8	20.2	18.8
6	5.3	4.5	4.9	52.6	72.7	63.4	42.1	22.7	31.7	7.6	5.9	6.8	73.6	78.2	75.8	18.7	15.9	17.4
7	8.1	9.4	8.7	86.5	75.0	81.2	5.4	15.6	10.1	7.0	5.5	6.3	77.0	80.0	78.4	16.0	14.5	15.3
8	8.0	9.1	8.5	88.0	90.9	89.4	4.0	0.0	2.1	5.8	4.5	5.2	77.7	80.4	78.9	16.5	15.1	15.9
9	2.9	3.2	3.1	90.1	91.9	91.0	7.0	4.9	5.9	4.7	4.1	4.4	79.2	82.0	80.5	16.1	13.9	15.1
10	2.3	1.6	1.9	89.3	92.4	90.8	8.4	6.1	7.2	4.7	4.0	4.4	80.2	82.8	81.4	15.1	13.3	14.3
11	3.1	2.5	2.8	86.8	88.5	87.6	10.1	9.0	9.6	5.0	4.2	4.6	80.8	82.7	81.7	14.1	13.2	13.7
12	4.5	4.1	4.3	84.8	84.4	84.6	10.7	11.4	11.0	5.9	5.1	5.6	80.2	81.5	80.8	13.8	13.4	13.6
13	6.5	5.2	5.9	80.5	81.3	80.8	13.0	13.5	13.2	8.2	6.6	7.6	77.1	78.5	77.7	14.6	14.9	14.7
14	8.5	8.6	8.5	78.6	78.7	78.6	12.9	12.8	12.8	9.8	9.7	9.8	75.5	76.2	75.8	14.7	14.1	14.5
15	10.1	12.4	10.8	78.8	76.1	78.0	11.2	11.5	11.3	11.7	12.3	11.8	76.4	74.4	75.8	12.0	13.3	12.4
16	12.1	9.8	11.5	77.6	70.5	75.8	10.3	19.7	12.6	13.7	11.0	13.0	73.1	70.8	72.6	13.3	18.3	14.4
17	15.6	2.8	13.6	65.6	83.3	68.4	18.8	13.9	18.0	14.1	2.3	12.4	66.3	83.7	68.8	19.6	14.0	18.8
>18	23.1	33.3	25.0	71.8	33.3	64.6	5.1	33.3	10.4	23.1	23.1	23.1	63.5	38.5	58.5	13.5	38.5	18.5
Total	5.0	4.0	4.6	84.1	85.7	84.8	10.9	10.4	10.7	6.0	4.8	5.5	78.6	81.1	79.7	15.4	14.1	14.8

4. Middle level: Flow rates

Table 36. Middle level: Flow rates by age, grade and gender, 2007/08

Age	Grade 6									Grade 7								
	Dropout			Promotion			Repetition			Dropout			Promotion			Repetition		
	M	F	T	M	F	T	M	F	T	M	F	T	M	F	T	M	F	T
10	6.5	1.0	4.0	78.4	88.8	83.1	15.2	10.2	12.9	0.0	0.0	0.0	83.3	100.0	87.5	16.7	0.0	12.5
11	3.1	1.7	2.4	83.7	89.0	86.3	13.2	9.3	11.2	2.7	1.4	2.1	88.5	93.7	90.9	8.8	5.0	7.1
12	4.4	3.1	3.8	77.5	82.1	79.6	18.0	14.9	16.6	1.9	1.8	1.8	90.4	92.6	91.5	7.7	5.6	6.7
13	6.2	4.0	5.3	72.0	77.0	74.1	21.8	19.0	20.6	3.7	2.1	3.0	88.0	91.5	89.7	8.2	6.4	7.4
14	9.1	6.7	8.2	67.3	69.2	68.1	23.5	24.1	23.7	4.7	3.2	4.1	83.0	85.7	84.1	12.3	11.1	11.8
15	12.1	9.9	11.3	62.0	61.7	61.9	25.9	28.4	26.8	6.8	7.5	7.1	78.8	77.6	78.4	14.3	14.9	14.5
16	15.4	10.9	14.0	60.0	58.7	59.6	24.6	30.4	26.4	9.7	8.7	9.4	74.0	75.4	74.5	16.2	15.9	16.1
17	17.3	16.4	17.1	59.6	64.9	60.8	23.1	18.8	22.1	12.4	14.3	13.0	69.0	68.6	68.9	18.6	17.2	18.1
18	15.8	12.1	14.9	56.9	62.6	58.3	27.3	25.3	26.8	13.3	17.7	14.3	63.3	59.2	62.4	23.4	23.0	23.3
19	20.5	28.6	21.6	42.0	57.1	44.1	37.5	14.3	34.3	15.9	16.7	16.1	61.2	60.6	61.1	22.8	22.7	22.8
>20	17.6	18.2	17.9	64.7	45.5	57.1	17.6	36.4	25.0	13.2	0.0	10.0	63.2	91.7	70.0	23.7	8.3	20.0
Total	7.9	4.9	6.6	70.9	76.4	73.2	21.2	18.7	20.2	6.3	4.8	5.7	80.8	84.5	82.3	12.9	10.6	12.0

Age	Grade 8									Grade 6-8								
	Dropout			Promotion			Repetition			Dropout			Promotion			Repetition		
	M	F	T	M	F	T	M	F	T	M	F	T	M	F	T	M	F	T
10	0.0	0.0	0.0	100.0	100.0	100.0	0.0	0.0	0.0	6.3	1.0	3.9	78.6	88.9	83.3	15.1	10.1	12.8
11	0.0	0.0	0.0	100.0	75.0	80.0	0.0	25.0	20.0	3.1	1.7	2.4	84.1	89.3	86.7	12.8	9.0	10.9
12	0.0	1.9	1.1	97.6	89.5	94.1	1.9	8.6	4.9	3.7	2.7	3.2	81.0	84.9	82.9	15.2	12.4	13.9
13	1.9	1.6	1.7	92.2	93.9	93.1	5.9	4.5	5.2	4.8	2.9	3.9	80.3	85.2	82.5	14.9	11.9	13.5
14	3.0	3.0	3.0	89.7	91.9	90.6	7.3	5.5	6.4	5.8	4.2	5.1	79.1	82.6	80.6	15.1	13.2	14.3
15	4.6	5.7	5.1	85.5	85.5	85.5	9.9	8.8	9.4	7.4	7.3	7.4	76.7	77.4	77.0	15.8	15.3	15.6
16	6.5	8.3	7.3	78.8	80.1	79.3	14.7	11.6	13.4	9.5	8.8	9.2	73.3	75.3	74.0	17.2	15.8	16.7
17	8.4	10.7	9.3	75.1	77.1	75.9	16.4	12.2	14.9	11.2	12.2	11.5	70.6	73.6	71.6	18.2	14.2	16.9
18	9.0	11.8	10.0	72.3	72.9	72.5	18.6	15.2	17.5	10.9	13.0	11.5	68.3	69.6	68.7	20.8	17.4	19.8
19	12.1	13.3	12.5	68.7	65.3	67.5	19.3	21.4	20.0	13.9	14.3	14.0	64.2	64.3	64.3	21.9	21.4	21.7
>20	9.6	15.2	12.3	63.9	59.5	61.7	26.5	25.3	25.9	11.6	13.7	12.5	63.8	61.8	62.9	24.6	24.5	24.6
Total	5.6	6.1	5.9	82.4	84.8	83.4	12.0	9.0	10.7	6.7	5.3	6.1	77.3	81.4	79.0	16.0	13.3	14.9

5. Secondary level: Flow rates

Table 37. Secondary level: Flow rates by age, grade and gender, 2007/08

Age	Grade 9									Grade 10									
	Dropout			Promotion			Repetition			Dropout			Promotion			Repetition			
	M	F	T	M	F	T	M	F	T	M	F	T	M	F	T	M	F	T	
12	0.0	0.0	0.0	100.0	100.0	100.0	0.0	0.0	0.0	0.0	0.0	0.0	0.0	0.0	0.0	0.0	0.0	0.0	0.0
13	5.2	3.5	4.4	91.5	94.4	92.9	3.3	2.1	2.7	16.7	0.0	12.5	83.3	100.0	87.5	0.0	0.0	0.0	0.0
14	4.6	2.9	3.8	86.9	92.2	89.5	8.4	4.9	6.7	1.5	5.2	3.2	90.2	93.1	91.6	8.3	1.7	5.2	5.2
15	5.0	4.0	4.5	80.8	88.2	84.2	14.3	7.8	11.3	2.8	4.5	3.6	85.5	88.9	87.1	11.7	6.7	9.2	9.2
16	6.7	5.8	6.3	72.2	81.0	75.9	21.1	13.2	17.8	4.9	5.1	5.0	81.4	85.6	83.4	13.6	9.3	11.6	11.6
17	8.6	9.2	8.8	63.4	72.2	66.7	28.1	18.6	24.5	7.6	10.3	8.7	76.3	78.6	77.2	16.2	11.1	14.1	14.1
18	11.4	10.9	11.3	56.6	65.9	59.8	32.0	23.2	29.0	10.4	13.0	11.3	72.3	71.9	72.1	17.4	15.2	16.5	16.5
19	13.8	12.8	13.5	50.8	58.7	53.4	35.4	28.5	33.1	10.1	17.0	12.6	69.9	67.8	69.1	20.0	15.3	18.3	18.3
20	16.0	18.1	17.1	48.9	53.2	51.1	35.1	28.7	31.8	14.7	17.1	15.7	65.9	65.5	65.7	19.5	17.4	18.6	18.6
21	19.1	16.7	17.9	57.4	55.6	56.5	23.4	27.8	25.5	12.2	16.7	14.2	66.0	65.8	65.9	21.8	17.4	19.9	19.9
22	11.8	26.1	20.0	58.8	47.7	52.5	29.4	26.1	27.5	8.3	14.9	13.0	72.9	74.4	74.0	18.8	10.7	13.0	13.0
23	10.0	40.0	20.0	40.0	60.0	46.7	50.0	0.0	33.3	21.1	13.3	16.3	73.7	56.7	63.3	5.3	30.0	20.4	20.4
>24	28.6	33.3	29.6	71.4	50.0	66.7	0.0	16.7	3.7	10.7	8.7	9.8	82.1	78.3	80.4	7.1	13.0	9.8	9.8
Total	8.4	7.4	8.0	67.7	77.6	71.7	23.9	15.0	20.3	8.5	10.8	9.4	74.9	77.0	75.8	16.6	12.3	14.8	14.8

Age	Grade 11									Grade 9-11									
	Dropout			Promotion			Repetition			Dropout			Promotion			Repetition			
	M	F	T	M	F	T	M	F	T	M	F	T	M	F	T	M	F	T	
12	0.0	0.0	0.0	0.0	0.0	0.0	0.0	0.0	0.0	0.0	0.0	0.0	100.0	100.0	100.0	0.0	0.0	0.0	0.0
13	0.0	0.0	0.0	0.0	0.0	0.0	0.0	0.0	0.0	5.4	3.5	4.5	91.4	94.5	92.9	3.2	2.1	2.7	2.7
14	0.0	0.0	0.0	100.0	100.0	100.0	0.0	0.0	0.0	4.4	3.1	3.7	87.2	92.3	89.7	8.4	4.6	6.6	6.6
15	6.9	3.9	5.5	93.1	96.1	94.5	0.0	0.0	0.0	4.5	4.1	4.3	82.0	88.5	85.0	13.5	7.4	10.7	10.7
16	3.1	5.7	4.4	96.4	94.0	95.2	0.5	0.	0.4	5.9	5.5	5.7	77.1	84.0	80.1	17.1	10.5	14.2	14.2
17	5.0	8.4	6.6	94.5	91.1	92.9	0.5	0.4	0.5	7.6	9.4	8.3	73.4	78.8	75.6	19.0	11.8	16.1	16.1
18	6.9	12.4	9.2	91.6	86.2	89.2	1.5	1.5	1.5	9.9	12.1	10.7	70.9	74.3	72.2	19.2	13.6	17.1	17.1
19	7.4	12.5	9.2	90.4	85.4	88.6	2.2	2.1	2.2	10.3	14.3	11.7	71.2	71.7	71.4	18.5	14.0	16.9	16.9
20	9.6	15.1	11.3	88.3	81.0	86.1	2.0	3.9	2.6	11.9	16.5	13.6	76.9	69.4	74.1	11.2	14.1	2.3	2.3
21	6.7	17.3	10.2	89.8	79.4	86.4	3.4	3.3	3.4	9.4	17.0	12.3	80.0	71.4	76.8	10.6	11.6	11.0	11.0
22	7.4	12.6	9.9	88.5	84.7	86.7	4.1	2.7	3.4	8.0	14.9	12.0	81.8	76.5	78.7	10.2	8.6	9.3	9.3
23	9.8	9.5	9.7	88.2	90.5	89.2	2.0	0.0	1.1	12.5	13.0	12.7	78.8	75.3	77.1	8.8	11.7	10.2	10.2
>24	6.9	13.6	8.8	93.1	81.8	90.0	0.0	4.5	1.3	12.1	13.7	12.7	86.0	76.5	82.9	1.9	9.8	4.4	4.4
Total	6.8	11.2	8.6	91.5	87.1	89.8	1.7	1.6	1.6	8.1	9.3	8.6	75.2	79.5	76.9	16.7	11.2	14.5	14.5

6. Elementary level: Zoba flow rates

Table 38. Elementary level: Average flow rates, 2007/08

	Grade	1	2	3	4	5
	Eritrea	Dropout	8.2	4.9	4.8	4.9
	Promotion	77.3	75.9	80.1	80.5	84.8
	Repetition	14.5	19.2	15.1	14.5	10.7
Anseba	Dropout	8.4	5.0	5.8	6.1	5.8
	Promotion	79.1	75.9	80.0	78.1	82.7
	Repetition	12.5	19.1	14.2	15.8	11.5
Debub	Dropout	7.0	4.9	4.4	4.5	4.4
	Promotion	77.6	75.6	79.6	80.5	84.8
	Repetition	15.4	19.5	16.0	15.0	10.7
Deb-Keih-B	Dropout	9.1	5.7	5.4	5.6	3.8
	Promotion	69.1	76.0	78.8	78.0	89.2
	Repetition	21.8	18.3	15.8	16.3	7.1
Gash-Barka	Dropout	12.4	7.1	7.3	7.6	6.5
	Promotion	70.4	70.2	74.2	75.7	80.1
	Repetition	16.8	22.6	18.5	16.7	13.4
Maekel	Dropout	3.8	2.1	2.0	2.3	2.1
	Promotion	86.2	85.5	88.4	88.5	90.2
	Repetition	10.0	12.4	9.6	9.2	7.7
Sem-Keih-B	Dropout	11.7	5.8	5.4	5.6	5.7
	Promotion	70.9	69.3	77.0	75.1	81.9
	Repetition	17.4	24.9	17.6	19.3	12.4

7. Elementary level: Cohort Reconstruction

Figure 1-7 are constructed based on the actual flow rates of the 2007/08 academic year indicated in table 38.

Figure 1: Elementary level: hypothetical cohort reconstruction (Constant) ERITREA

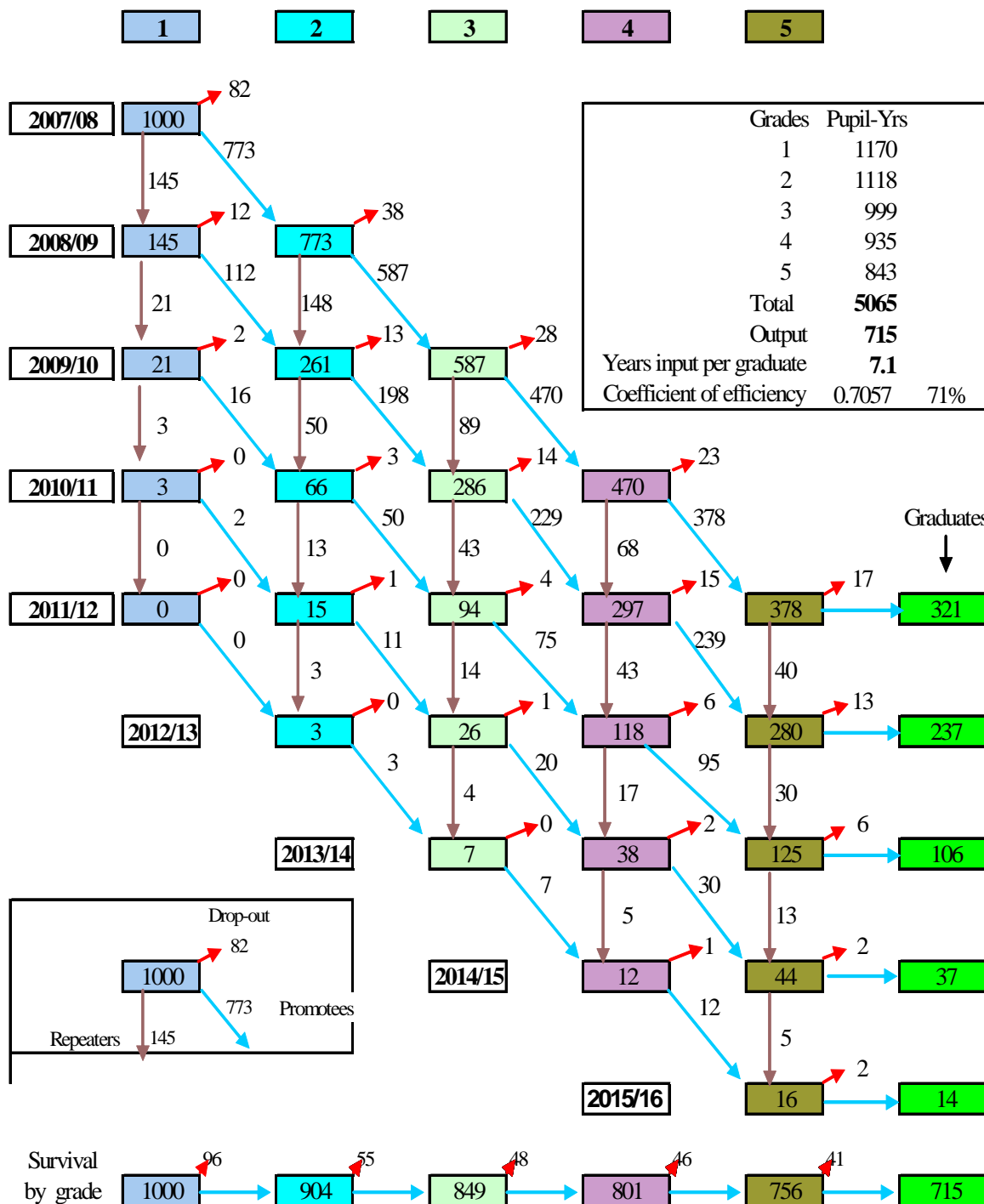

Table 39. Eritrea elementary level: Wastage, survival and transition rates by zoba

(Based on the 2007/08 flow rate and cohort reconstruction of each zoba)

	Internal efficiency ratios	T	ANS	DKB	DEB	GASH	MAKL	SKB
1	Elementary level: Wastage ratio	1.42	1.47	1.46	1.41	1.64	1.2	1.56
2	Survival ratio for Grade 2	90.4	90.4	88.4	91.7	85.1	95.8	85.8
	Survival ratio for Grade 3	84.9	84.8	82.2	86.1	77.3	93.5	79.2
	Survival ratio for Grade 4	80.1	79.1	77.0	81.6	70.4	91.4	74.0
	Survival ratio for Grade 5	75.6	73.4	71.8	77.3	64.0	89.1	68.9
3	Transition ratio from elementary level to middle level (No national exam.)	71.5	68.4	68.7	73.2	59.0	87.0	64.1
4	Proportion of total waste spent due to dropouts	49.3	53.8	47.8	46.7	54.6	40.3	48.7
5	Proportion of total waste spent due to repetition	50.7	46.2	52.2	53.3	45.4	59.7	51.3
6	Average length of study per graduate	7.1	7.3	7.3	7.1	8.2	6.0	7.8

Chart 13. Elementary level Average length of study per student (ALSS) by zoba

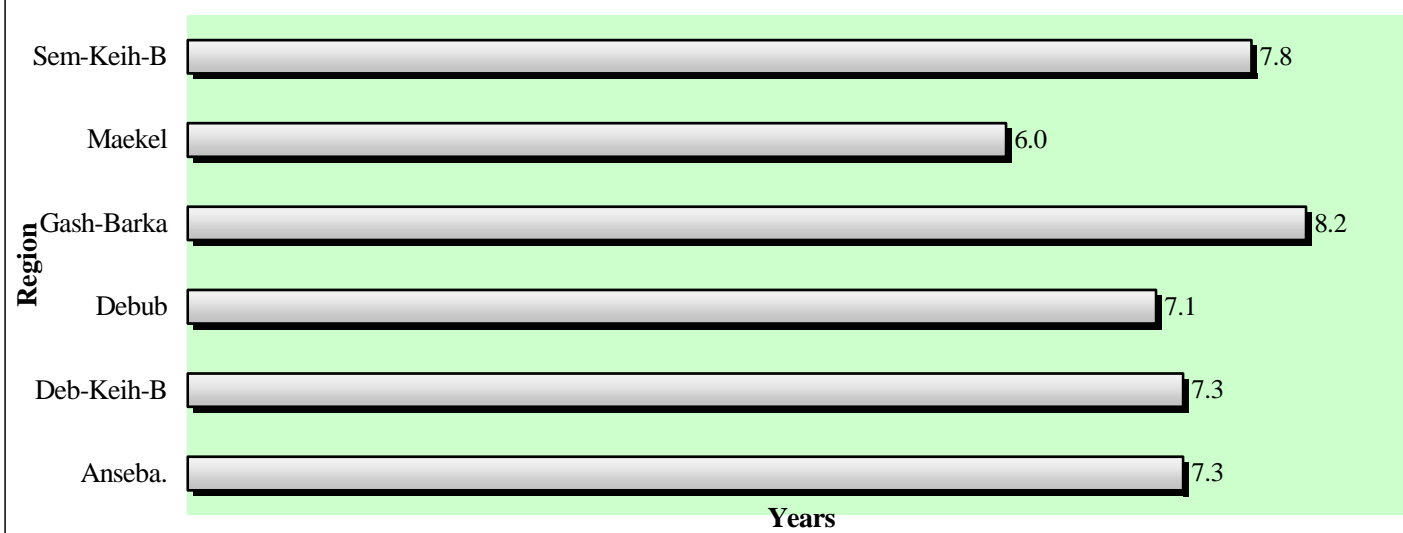
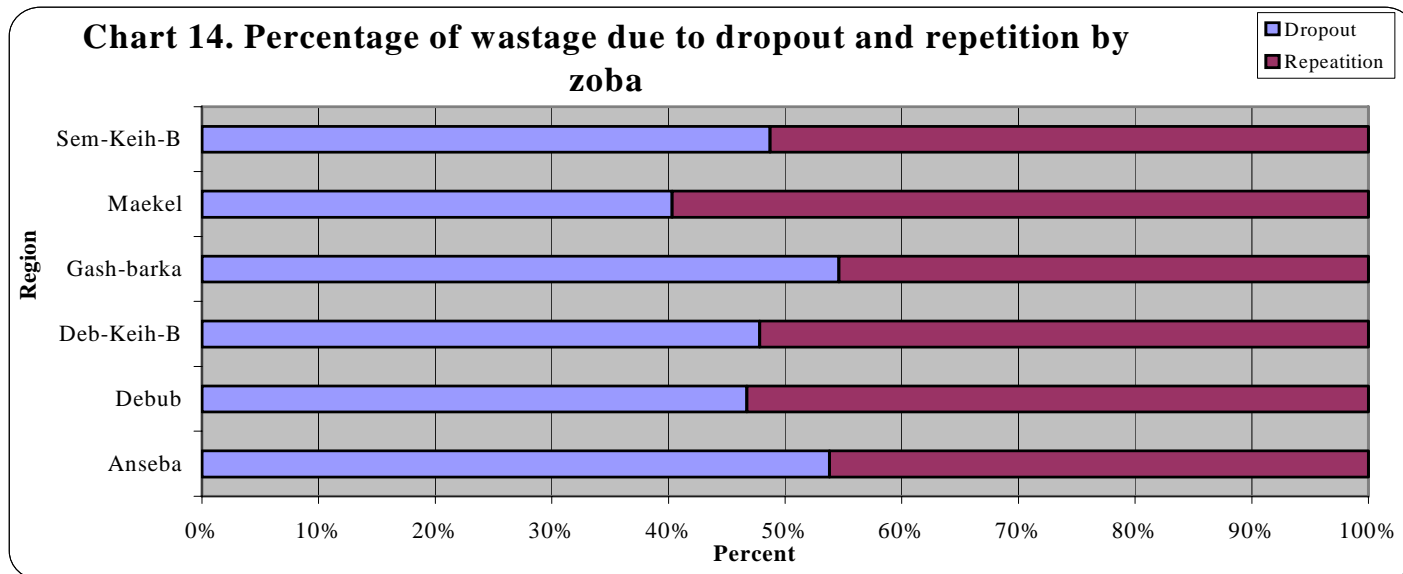

Chart 14. Percentage of wastage due to dropout and repetition by zoba



IX. Teaching staff: Elementary, middle and secondary level**Table 40. Teachers: Gender and level by zoba, 2007/08**

Zoba	1-5			6-8			9-12			Total		
	T	M	F	T	M	F	T	M	F	T	M	F
Anseba	1,239	795	444	417	400	17	178	164	14	1,834	1,359	475
Debub	2,138	1,017	1,121	851	775	76	493	420	73	3,482	2,212	1,270
Deb-Keih-B	171	147	24	41	39	2	40	40	0	252	226	26
Gash-Barka	1,467	1,089	378	354	338	16	160	156	4	1,981	1,583	398
Maekel	1,676	540	1,136	832	691	141	641	523	118	3,149	1,754	1,395
Sawa	0	0	0	0	0	0	180	179	1	180	179	1
Sem-Keih-B	620	482	138	209	203	6	119	105	14	948	790	158
Total	7,311	4,070	3,241	2,704	2,446	258	1,811	1,587	210	11,826	8,103	3,709

1. Pupil/teacher ratio: Elementary, middle and secondary level

This ratio represents the average number of pupils per teacher at each level.

Table 41. Pupil /teacher ratio by year and level, 1991/92-2007/08

Year	Level								
	1-5			6-7			8-11		
	Pupil	Teacher	Pupil/teacher ratio	Pupil	Teacher	Pupil/teacher ratio	Pupil	Teacher	Pupil/teacher ratio
1991/92	150,982	3,647	41	27,917	783	36	27,627	758	36
1992/93	184,656	4,978	37	28,431	855	33	31,531	905	35
1993/94	208,199	5,272	39	32,781	978	34	32,756	1,015	32
1994/95	224,287	5,583	40	34,995	948	37	36,728	1,081	34
1995/96	241,725	5,828	41	39,751	992	40	39,188	1,039	38
1996/97	240,737	5,476	44	47,460	1,017	47	40,594	942	43
1997/98	247,499	5,799	43	57,152	1,162	49	41,615	959	43
1998/99	26,1963	5,576	47	67,021	1,208	56	47,533	982	49
1999/00	29,5941	6,229	48	74,317	1,312	57	57,334	1,047	55
2000/01	298,691	6,668	45	76,564	1,377	56	63,951	1,188	54
2001/02	330,278	7,498	44	80,882	1,529	53	70,183	1,419	50
2002/03	359,423	7,692	47	87,019	1,614	54	72,818	1,277	57
	1-5			6-8			9-12		
2003/04	374,997	8,033	47	122,966	2,241	55	69,401	1,645	43
2004/05	377,512	7,942	48	139,029	2,449	57	76,051	1,607	47
2005/06	364,263	7,711	47	148,082	2,491	59	77,644	1,552	50
2006/07	331,855	6,933	48	141,081	2,478	57	75,800	1,778	43
2007/08	314,034	7,311	43	144,031	2,704	53	83,411	1,811	46

2. Teachers' qualifications

Teachers in the elementary level are considered professionally qualified if they are graduates of the TTI or have an equivalent / higher qualification.

Teachers in the middle level are considered professionally qualified if they have a qualification of higher education diploma (12+2) or have an equivalent or higher qualification.

Teachers in the secondary level are considered professionally qualified if they have a minimum qualification of Bachelor degree.

Table 42. Teachers' qualifications, 2007/08

Year	Level								
	1-5			6-7			8-11		
	Total	qualified	Percent	Total	Qualified	Percent	Total	Qualified	Percent
1991/92	N.A	N.A	N.A	N.A	N.A	N.A	N.A	N.A	N.A
1992/93	4,978	2,128	42.7	855	484	56.6	905	431	47.6
1993/94	5,272	2,062	39.1	978	710	72.6	1,015	479	47.2
1994/95	5,583	2,675	47.9	948	661	69.7	1,081	507	46.9
1995/96	5,828	4,218	72.4	992	490	49.4	1,039	540	52.0
1996/97	5,476	3,747	68.4	1,017	446	43.9	942	527	55.9
1997/98	5,799	3,915	67.5	1,162	500	43.0	959	682	71.1
1998/99	5,576	4,058	72.8	1,208	459	37.9	982	715	72.8
1999/00	6,229	4,472	71.8	1,312	420	32.0	1,047	729	69.6
2000/01	6,668	4,699	70.5	1,377	486	35.3	1,188	869	73.1
2001/02	7,498	5,456	72.8	1,529	471	30.8	1,419	1,032	72.7
2002/03	7,692	6,194	80.5	1,614	507	31.4	1,277	870	68.1
	1-5			6-8			9-12		
2003/04	8,033	6,675	83.1	2,241	633	28.2	1,645	1,294	78.6
2004/05	7,942	6,640	83.6	2,449	708	28.9	1,607	1,311	81.6
2005/06	7,711	6,749	87.5	2,491	709	28.5	1,552	1,276	82.2
2006/07	6,933	6,039	87.1	2,478	911	36.8	1,778	1,524	85.7
2007/08	7,311	6,594	90.2	2,704	1,137	42.0	1,811	1,453	80.2

3. Female teachers

Table 43. Number and percentage of female teachers by level, 1991/92-2007/08

Year	1-5			6-7			8-11		
	T	F	% of F	T	F	% of F	T	F	% of F
1991/92	3,647	1,411	38.7	783	139	17.8	758	67	8.8
1992/93	4,978	1,849	37.1	855	143	16.7	905	93	10.3
1993/94	5,272	1,865	35.4	978	140	14.3	1,015	104	10.2
1994/95	5,583	1,974	35.4	948	139	14.7	1,081	108	10.0
1995/96	5,828	2,025	34.7	992	156	15.7	1,039	103	9.9
1996/97	5,476	1,977	36.1	1,017	170	16.7	942	106	11.3
1997/98	5,799	1,893	32.6	1,162	170	14.6	959	113	11.8
1998/99	5,576	1,951	35.0	1,208	149	12.3	982	112	11.4
1999/00	6,229	2,330	37.4	1,312	167	12.7	1,047	109	10.4
2000/01	6,668	2,710	40.6	1,377	160	11.6	1,188	115	9.7
2001/02	7,498	2,873	38.3	1,529	177	11.6	1,419	145	10.2
2002/03	7,692	2,754	35.8	1,614	178	11.0	1,277	140	11.0
	1-5			6-8			9-12		
2003/04	8,033	2,887	35.9	2,241	216	9.6	1,645	215	13.1
2004/05	7,942	3,166	39.9	2,449	245	10.0	1,607	215	13.4
2005/06	7,711	3,350	43.4	2,491	314	12.6	1,552	204	13.1
2006/07	6,933	3,305	47.7	2,478	245	10.0	1,778	208	11.7
2007/08	7,311	3,241	44.3	2,704	258	10.5	1,811	210	11.6

In elementary and middle levels only directors are included in teaching staff where as in secondary level directors and other staffs that is actively participated in teaching and learning process are included.

X. Age-specific enrolment, 2007/08

Table 44. Age-specific enrolment, 2007/08

Age	School Age population		Pre-primary		Elementary		Middle		Secondary		Enrolment %	
	T	F	T	F	T	F	T	F	T	F	T	F
0	151467	76438										
1	127986	64094										
2	110215	54687										
3	97524	47897	703	354							0.72	0.74
4	89267	43402	10,254	4,971							11.49	11.45
5	84810	40878	19,457	9,401	127	60					23.09	23.14
6	83514	40009	5,140	2,510	20,405	9,543					30.59	30.13
5-6	168,324	80,887	24,597	11,911	20,532	9,603					26.81	26.60
7	84740	40470	246	141	39,736	18,626					47.18	46.37
8	87853	41940	33	14	44,102	20,420					50.24	48.72
9	92211	44098			49,657	23,030					53.85	52.22
10	97993	47004			54,252	25,193	503	258			55.88	54.15
11	105368	50716			45,843	20,505	7,286	3,616			50.42	47.56
7-11	468,165	224,228	279	155	233,590	107,774	7,789	3,874			51.62	49.86
12	109639	53010			31,487	13,338	20,187	9,528	31	20	47.16	43.17
13	108544	52806			17,167	6,550	29,913	13,524	749	351	44.06	38.68
14	103879	50923			7,225	2,512	30,470	13,022	3,232	1,554	39.40	33.56
12-14	322,062	156,739			55,879	22,400	80,570	36,074	4,012	1,925	43.61	38.53
15	99824	49361			2,741	758	23,634	9,283	8,719	4,027	35.16	28.50
16	95675	47835			949	203	16,304	6,045	13,433	5,917	32.07	25.43
17	91103	45833			278	42	10,062	3,284	16,868	6,719	29.87	21.92
18	86406	43339			0	0	4,232	1,291	17,241	6,647	24.85	18.32
15-18	373,008	186,368			3,968	1,003	54,232	19,903	56,261	23,310	30.69	23.73
19	81573	40525					1,232	313	12,958	4,850		
20	76452	37624							6,027	2,290		
21	71250	34634							2,884	1,067		
22	65954	31907							730	411		
23	60589	29649							236	127		
24	55392	27788							303	108		
25	50294	25900			65	12	208	101				
26	44985	23898										
27	41675	22782										
28	41357	22951										
29	42924	23907										
30	44425	24854										
			35,833	17,391	314,034	140,792	144,031	60,265	83,411	34,088		